



DIFFERENTIAL PROBING SYSTEM



SERIES D13000PS AND D11000PS OPERATOR'S MANUAL

REVISION A – DECEMBER, 2007



LeCroy Corporation

700 Chestnut Ridge Road
Chestnut Ridge, NY 10977-6499
Tel: (845) 578 6020, Fax: (845) 578 5985

Internet: www.lecroy.com

Warranty

LeCroy warrants this oscilloscope accessory for normal use and operation within specification for a period of one year from the date of shipment. Spare parts, replacement parts and repairs are warranted for 90 days.

In exercising its warranty, LeCroy, at its option, will either repair or replace any assembly returned within its warranty period to the Customer Service Department or an authorized service center. However, this will be done only if the product is determined by LeCroy's examination to be defective due to workmanship or materials, and the defect is not caused by misuse, neglect, accident, abnormal conditions of operation, or damage resulting from attempted repair or modifications by a non-authorized service facility.

The customer will be responsible for the transportation and insurance charges for the return of products to the service facility. LeCroy will return all products under warranty with transportation charges prepaid.

This warranty replaces all other warranties, expressed or implied, including but not limited to any implied warranty of merchantability, fitness or adequacy for any particular purposes or use. LeCroy shall not be liable for any special, incidental, or consequential damages, whether in contract or otherwise.

© 2007 by LeCroy Corporation. All rights reserved.

LeCroy, ActiveDSO, WaveLink, JitterTrack, WavePro, WaveMaster, WaveSurfer, WaveExpert, WaveRunner and WaveJet are registered trademarks of LeCroy Corporation. Other product or brand names are trademarks or requested trademarks of their respective holders. Information in this publication supersedes all earlier versions. Specifications subject to change without notice.

Manufactured under an
ISO 9000 Registered
Quality Management
System

Visit www.lecroy.com to view
the certificate.



This electronic product is subject to disposal and recycling regulations that vary by country and region. Many countries prohibit the disposal of waste electronic equipment in standard waste receptacles.

For more information about proper disposal and recycling of your LeCroy product, please visit www.lecroy.com/recycle.

DPS-OM-E Rev A
915646-00



DECLARATION OF CONFORMITY

according to ISO/IEC Guide 22 and EN 45014:1998

Manufacturer's Name: LeCroy Corporation
Manufacturer's Address: 700 Chestnut Ridge Road
Chestnut Ridge, NY 10977
USA
Differential Probe

herewith declare that

Product(s) Name: D13000PS/ D11000PS
Model Number(s):

including all their options are in conformity with the provisions of the following EC directive(s), including the latest amendments, and with national legislation implementing these directives:

73/23/EEC Low Voltage Directive
89/336/EEC EMC Directive

and that conformity with Council Directive 73/23/EEC is based on

EN 61010-031: 2002 Safety requirements for electrical equipment for measurement, control and laboratory use
Part 031: Safety requirements for hand-held probe assemblies for electrical measurement and test

and that conformity with Council Directive 89/336/EEC is based on

EN 61326-1:1997+A1:1998+A2:2001 EMC requirements for electrical equipment for measurement, control and laboratory use

Emissions EN 55011:1998+A1:1999 Radiated Emissions
Immunity: EN 61000-4-2:1995+A2:2002 Electrostatic Discharge
EN 61000-4-3:2002 RF Radiated Electromagnetic Field



By: David C. Graef
Vice President & Chief Technology Officer

European Contact:
Your local LeCroy Sales Office or

Place: LeCroy Corporation
700 Chestnut Ridge Road
Chestnut Ridge, NY 10977
USA

LeCroy Europe GmbH
Waldhofer Str. 104
D-69123 Heidelberg
Germany

Date: July 26, 2005

Tel: (49) 6221 82700
Fax: (49) 6221 834655

Warning: This is a Class A product. In a domestic environment this product may cause radio interference, in which case the user may be required to take adequate measures.

BLANK PAGE

TABLE OF CONTENTS

OVERVIEW.....8
DESCRIPTION..... 8
APPLICATIONS..... 9
D13000PS STANDARD ACCESSORIES..... 10
D11000PS STANDARD ACCESSORIES..... 10
COMPONENTS AND ACCESSORIES.....13
FEATURES..... 13
 Probe Body..... 13
 Probe Module..... 13
 AutoColor ID..... 13
STANDARD ACCESSORIES..... 14
 Solder-In Interconnect Lead..... 14
 To achieve the highest frequency response and minimize parasitic inductance, the damping resistors are not field replaceable. The leads must be replaced when damaged..... 14
 SMA Interconnect Lead..... 14
 SMA Input Leads..... 15
 SMP Input Leads (D13000PS Only)..... 15
 Ground Lead and Clip..... 15
 SMA DC Blocking Adapter..... 16
 SMA Finger Wrench..... 16
POSITIONING AIDS AND RETAINING DEVICES..... 17
 Tip Retaining Clip..... 17
 Probe Body Clamp Set..... 17
 FreeHand Probe Holder..... 17
OPERATION.....18
HANDLING THE PROBE..... 18
CONNECTING A MODULE TO THE PROBE BODY..... 18
CONNECTING THE SOLDER-IN AND SMA LEADS TO THE PROBE MODULE..... 19
INTERCHANGEABILITY AND CALIBRATION..... 20
COMPATIBILITY..... 20
CONNECTING THE PROBE TO A LECROY SERIAL DATA ANALYZER..... 21
AUTOCOLOR ID..... 21
AUTOZERO..... 21
COMMON MODE DISPLAY..... 21
OPERATION WITH AN SDA 13000/11000..... 22
CONNECTING THE PROBE TO THE TEST CIRCUIT..... 23
 Solder-In Tip Module..... 24
 SMA Tip Module..... 25
USE OF DC BLOCKING ADAPTER..... 26
POSITIONING OF THE INPUT LEADS..... 26

WAVELINK DIFFERENTIAL PROBE

POSITIONING TOOLS	26
Tip Retaining Clip.....	26
Attaching the Probe	28
Tip Retaining Clip Removal	28
Probe Body Location Clip	29
FreeHand Probe Holder.....	30
PROBE GROUNDING	30
OFFSET	31
DYNAMIC RANGE	31
CARE AND MAINTENANCE.....	33
CLEANING	33
SERVICE STRATEGY	33
RETURNING A PROBE FOR CALIBRATION OR SERVICE.....	33
RETURNING A PROBE TO A DIFFERENT COUNTRY	34
REPLACEMENT PARTS	35
REFERENCE INFORMATION.....	37
PROBE INPUT LOADING.....	37
DIFFERENTIAL MODE AND COMMON MODE	38
DIFFERENTIAL MODE RANGE AND COMMON MODE RANGE.....	38
COMMON MODE REJECTION RATIO	39
FUNCTIONAL TEST	40
INTRODUCTION.....	40
TEST	40
PERFORMANCE VERIFICATION.....	45
INTRODUCTION.....	45
TEST EQUIPMENT REQUIRED.....	46
PRELIMINARY PROCEDURE.....	48
VERIFICATION PROCEDURE.....	49
Actual Probe Attenuation	49
Output Zero.....	53
Attenuation Accuracy	54
Rise Time (10% to 90%).....	57
SPECIFICATIONS.....	62
NOMINAL CHARACTERISTICS	62
General	62
D13000PS/ D11000PS CHARACTERISTICS	63
ENVIRONMENTAL CHARACTERISTICS	67
PHYSICAL CHARACTERISTICS	67
COMPLIANCE AND CERTIFICATIONS.....	67
CAUTION.....	68
APPENDIX A	69

OPERATOR'S MANUAL

PERFORMANCE VERIFICATION TEST RECORD 69
ITEMS TESTED 69
EQUIPMENT USED 70
EQUIPMENT USED 70
TEST RECORD 70
 Actual Probe Attenuation 70
 Output Zero 70
 Attenuation Accuracy 70
 Rise Time 70

WAVELINK DIFFERENTIAL PROBE

OVERVIEW

DESCRIPTION

The D13000PS/D11000PS Differential Probing System is a very high band-width active differential probe. The probe features low noise, very low input loading and high common mode rejection and is designed to be used exclusively with the SDA13000/SDA 11000 Serial Data Analyzer.

The dynamic range, system attenuation, input impedance was designed to optimize performance for use with these types of signals.

The D13000PS/D11000PS system consists of probe body, probe module and interconnect leads and provides two types of interconnection to the test circuit;

- Direct solder-in
- Direct cable attachment to female SMA connectors
- Direct cable attachment to female SMP connectors (D13000PS only).

A dedicated module is used for each connection type. Each has a plug in lead for the respective interconnect type. To prevent accidental reversal of the leads with modules, each is color coded. Purple is for the Solder-In and blue-green for the SMA/SMP leads.

The SMA/SMP interconnect has two parts. An interconnect “lead” which plugs into the module and two cables which plug into the interconnect lead. A network, at the end of this interconnect lead at the point where the SMA/SMP cables attach, attenuates the signal for the correct scale factor as well as provides some response compensation.

The SMA/SMP Input cables must always be used with the SMA interconnect Lead. Calibration is not dependent on these leads. However they are a matched pair, so individual cables should not be interchanged between probes.

Note

The SMA/SMP leads use the same connectors as in the interconnect leads and will physically mate with the probe tip module. However, the system will not work properly in this configuration. No damage to the probe or amplifier will occur. However, maximum voltage to prevent destruction will be much lower and the susceptibility to ESD is reduced.

Probe Module:

The probe body contains common circuitry such as power supply, communication and control and AutoColor ID. The D13000PS/D11000PS system utilizes digital filtering to improve the system frequency response. The response is corrected through the use of digital filters which are specifically tailored through calibration to optimize the frequency flatness of each individual probe. This, combined with the exceptional probe loading characteristics, provides the highest fidelity in eye pattern measurement.

A Certificate of Calibration is supplied with each probe indicating that the system will meet the specifications with those components listed in the Certificate.



ESD Sensitive: The probe tips of the D13000PS/D11000PS probes are sensitive to Electrostatic Discharge (ESD). To avoid causing damage to the probe, always follow anti-static procedures (wear wrist strap, etc.) when using or handling the probe.

APPLICATIONS

The D13000PS/D11000PS Probes are ideally suited for acquiring differential signals common in high-speed serial data applications with fine pitch ICs and high lead count where high-speed, minimal loading and accurate jitter measurement are required:

- System Designers:
Designing systems using standard and ASIC components
Use simulators and correlate with lab measurements
- IC Designers:
Characterize new chip design
- Manufacturers of servers, PC Motherboards, Data routers, Disk drives
- High Speed SERDES

WAVELINK DIFFERENTIAL PROBE

D13000PS STANDARD ACCESSORIES

- Probe Body
- Probe Module – Solder-In
- Probe Module – SMA Direct Connect
- Solder-In Interconnect Lead (2)
- SMA Interconnect Lead
- Matched SMP Input Cables (1 pair)
- SMA Adapters
- Module ground lead and clip
- Tip Retaining Clip kit for Solder-In lead (2)
- SMA DC Blocking adapters (2)
- SMA tightening thumb wrench (2)
- Probe Body Clamp Set
- FreeHand Probe Holder
- SAC-01 Soft Accessory Case with insert
- Small Accessory case
- ESD Dissipating Wrist Strap
- D13000PS/D11000PS Instruction Manual
- Certificate of Calibration

D11000PS STANDARD ACCESSORIES

- Probe Body
- Probe Module – Solder-In
- Probe Module – SMA Direct Connect
- Solder-In Interconnect Lead (2)
- SMA Interconnect Lead
- Matched SMP Input Cables (1 pair)
- Module ground lead and clip
- Tip Retaining Clip kit for Solder-In lead (2)
- SMA DC Blocking adapters (2)
- SMA tightening thumb wrench (2)
- Probe Body Clamp Set
- FreeHand Probe Holder

- SAC-01 Soft Accessory Case with insert
- Small Accessory case
- ESD Dissipating Wrist Strap
- D13000PS/D11000PS Instruction Manual
- Certificate of Calibration

###

BLANK PAGE

COMPONENTS AND ACCESSORIES

FEATURES

Probe Body

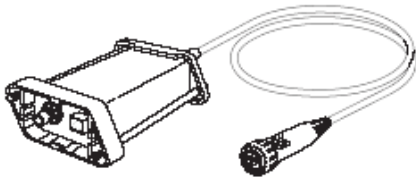

The small, low mass D13000PS/D11000PS Differential Probing System is designed for ease of use and high frequency performance with the SDA 13000/SDA 11000 Serial Data Analyzer.

Each probe is made up of two different components:

Probe Body and Probe Tip Module (See below for a description of each component).

Probe Module

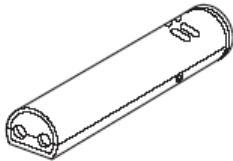

The Probe Module allows two types of interconnect leads, the Solder-In tip module and SMA tip module for direct cable connection to female SMA/SMP connectors

AutoColor ID

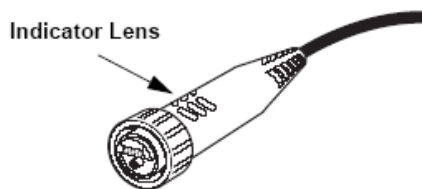

AutoColor ID LED, located in probe body, illuminates the probe body in the default color of the channel to which the probe is connected.

WAVELINK DIFFERENTIAL PROBE

STANDARD ACCESSORIES

Solder-In Interconnect Lead

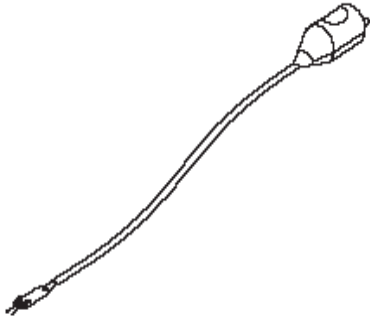

The Solder-In Interconnect Lead is supplied with two pre-installed damping resistors. The user solders the free end of the damping resistors directly to the test points on the circuit under test.

Because the resistors and lead lengths are small, this type of Interconnect Lead will give the maximum signal fidelity at the highest frequencies.

An extra Interconnect lead is supplied to reduce downtime while a replacement is being ordered.

To achieve the highest frequency response and minimize parasitic inductance, the damping resistors are not field replaceable. The leads must be replaced when damaged.

SMA Interconnect Lead

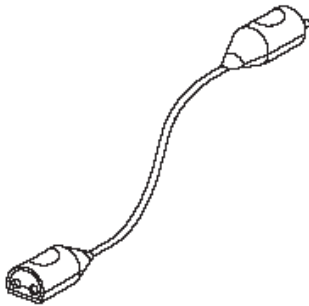

The SMA Interconnect Lead needs to be used in between the probe module and the SMA/SMP Input cables.

SMA Input Leads

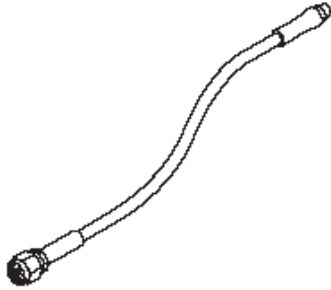

A matched pair of 50 Ω SMA Input Cables is provided for direct cable connection to female SMA connectors.

Note

The SMA Input Leads are not intended to be connected directly into the Probe Module. No damage to the probe or amplifier will occur. However maximum voltage to prevent destruction will be much lower and the susceptibility to ESD is reduced.

SMP Input Leads (D13000PS Only)

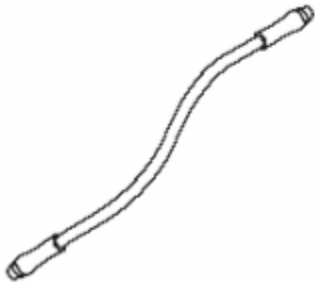

A matched pair of 50 Ω SMA Input Cables is provided for direct cable connection to female SMP connectors.

Note

The SMP Input Leads are not intended to be connected directly into the Probe Module. No damage to the probe or amplifier will occur. However maximum voltage to prevent destruction will be much lower and the susceptibility to ESD is reduced.

Ground Lead and Clip

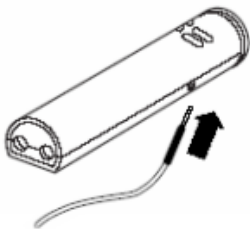

This Ground Lead, PACC-LD005, and the Ground Clip, PK006-4, can be used to connect the probe to ground of the circuit under test. The plug of the ground lead connects to the receptacle located on the side of the probe body.

The Ground Lead and Clip is supplied as a standard accessory to the D13000PS/D11000PS series probes.

The ground lead is not intended to be used with high frequency measurements, but to ground floating test circuits to keep the common mode within the maximum specified range.

WAVELINK DIFFERENTIAL PROBE

SMA DC Blocking Adapter

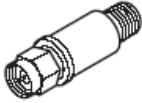

The SMA DC Blocking adapter can be used to extend the common mode or differential mode range by removing any DC component which exceeds the range. This would most likely be a common mode component.

Refer to section 9, Specification, for maximum allowable input voltages.

SMA Finger Wrench

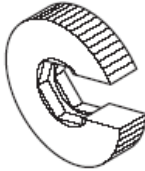

The SMA Finger Wrench is used for ease of tight-ening the SMA connectors.

POSITIONING AIDS AND RETAINING DEVICES

Tip Retaining Clip

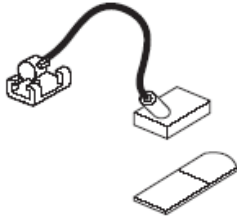

The Tip Retaining Clip, PK600ST-3, is an aid to allow the Solder-In Interconnect Leads to be held in place while making measurements or when soldering the damping resistors to the test points of the board under test.

The Clip is supplied as a standard accessory and comes with package of 20 adhesive pads for mounting the clip the board.

Probe Body Clamp Set

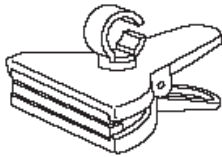

The Probe Body Clamp Set, PK600ST-4, can be used to give support to the probe and Interconnect Lead when the test points are located close to the edge of the board under test.

The PK600ST-4 includes one Board Edge Clip and four Adhesive Backed Probe Body Clamps.

FreeHand Probe Holder

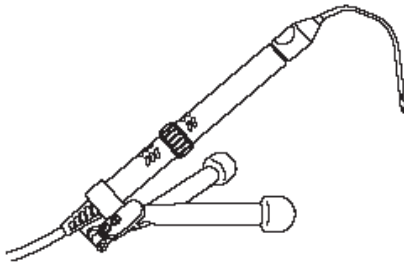

The FreeHand Probe Holder, PACC-MS001, provides an alternative method of holding the probe body to keep the cable weight off the Solder-In tip when an edge to clip the Probe Body Clamp is not available.

The FreeHand probe holder is supplied as a standard accessory.

WAVELINK DIFFERENTIAL PROBE

OPERATION

HANDLING THE PROBE

The D11000PS Differential Probe is a precision test instrument; exercise care when handling and storing the probe. Always handle the probe by the probe body or interface box. Avoid putting excessive strain on the cable or exposing the probe cable to sharp bends.



ESD Sensitive: The probe tips of the D13000PS/D11000PS probes are sensitive to Electrostatic Discharge (ESD). To avoid causing damage to the probe, always follow anti-static procedures (wear wrist strap, etc.) when using or handling the probe.

CONNECTING A MODULE TO THE PROBE BODY

To attach the Probe Module to the probe body, align the connectors of the module with the receptacles in the probe body and press the two together. Finger tighten the assembly by rotating the threaded collar onto the module.

Note

Do not use pliers to tighten collar.

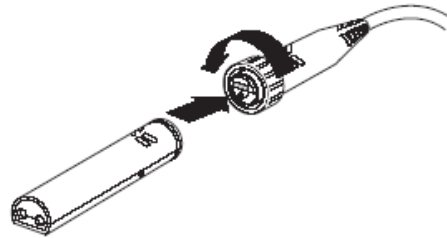

Figure 1. Attaching the Probe Module

Remove the Probe Module by loosening the threaded collar from the module and pulling the assemblies apart.

CONNECTING THE SOLDER-IN AND SMA LEADS TO THE PROBE MODULE

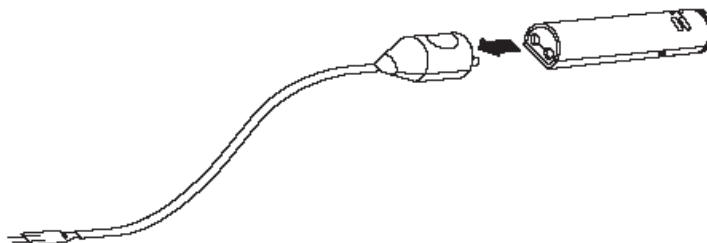

Figure 2. Attaching the Solder-In Lead

Align the flat side of the Solder-In Lead or SMA Interconnect Lead with the flat side of the Probe Module and press together.

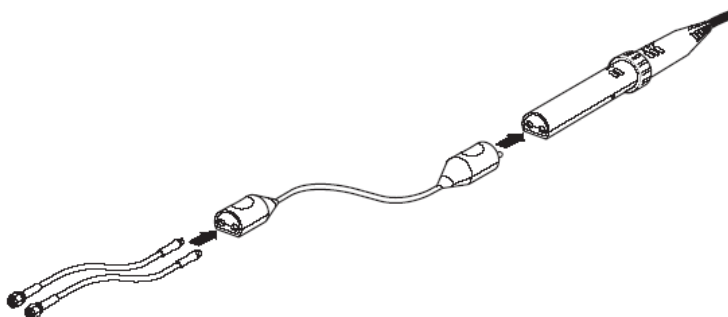

Figure 3. Attaching the SMA Interconnect Lead and Matched Set of SMA Input Cables

Connecting the 50 Ω SMA Interconnect Lead to the Probe Module is the same as with the SI Lead. Align the flat sides and push together. The SMA Input Lead connectors will then connect to the female connectors of the SMA Interconnect Lead.

Note

The SMA Input Leads use the same connector as the SMA Interconnect Lead and will physically mate directly with the Probe Module. However, the system will not work properly in this configuration. No damage to the probe or amplifier will occur. However maximum voltage to prevent destruction will be much lower and the susceptibility to ESD is reduced.

WAVELINK DIFFERENTIAL PROBE

INTERCHANGEABILITY AND CALIBRATION

Each configured probe is shipped with a Certificate of Calibration indicating that the system performance was validated and found to meet or exceed the warranted specifications with those models and accessories listed in the Certificate.

As only this configuration was validated, the certificate is only valid for the configuration indicated.

For repair or calibration, the entire probe with the interconnect leads should be sent back.

For repair of the interconnect leads, only the interconnect leads need to be returned.

COMPATIBILITY

The D13000PS/D11000PS Differential Probing System is designed to be used exclusively with the SDA 13000/11000 Serial data Analyzer. However it includes frequency compensation data compatible with lower BW WaveMaster, SDA and DDA 5005 oscilloscopes.

WaveLink probes look similar and mate mechanically with the D13000PS/D11000PS probe body. However, WaveLink modules are not designed to operate with the D13000PS/D11000PS body. Connecting a non compatible module to a probe body will not damage either the probe body or the module, but the oscilloscope will not identify the probe correctly, nor will the probe's compensation data be correctly loaded into the oscilloscope. This may result in distortion in waveform display.

CONNECTING THE PROBE TO A LECROY SERIAL DATA ANALYZER

The D13000PS/D11000PS probe system has been designed for exclusive use with the SDA 13000/11000 Serial Data Analyzer.

To attach the probe to the test instrument, align the interface connector with the input connector and push the interface toward the instrument.

A click will be heard when the probe's interface latches to the test instrument. This probe also uses the thumb screws to secure the interface to the instrument. **Do not overtighten the thumb screws.**

To remove the D13000PS/D11000PS probe from the instrument unscrew the thumb screws, move the interface up and down while pulling gently till a loud snap is heard indicating that the probe is unlatched from the instrument.

AUTOCOLOR ID

When the probe is connected to a SDA 11000, the LED will illuminate in the default color of the channel to which the probe is connected.

AUTOZERO

The D13000PS/D11000PS probe system incorporates an AutoZero function to remove any DC offset from the probe. This function must be invoked by the user.

After several minutes of warm-up, or when the probe is exposed to large shift in ambient temperature, some DC offset may occur and an AutoZero cycle should be initiated.

To start an Auto Zero cycle, remove the probe from the circuit under test and touch the screen's 'AutoZero' to remove output offset drift.

COMMON MODE DISPLAY

The D13000PS/D11000PS probe can detect the DC component of the common mode voltage of the signal under test and report this in the probe menu. The Common Mode Display will not work when DC blocking capacitors are used. Touch the Refresh tab to update the readout.

WAVELINK DIFFERENTIAL PROBE

OPERATION WITH AN SDA 13000/11000

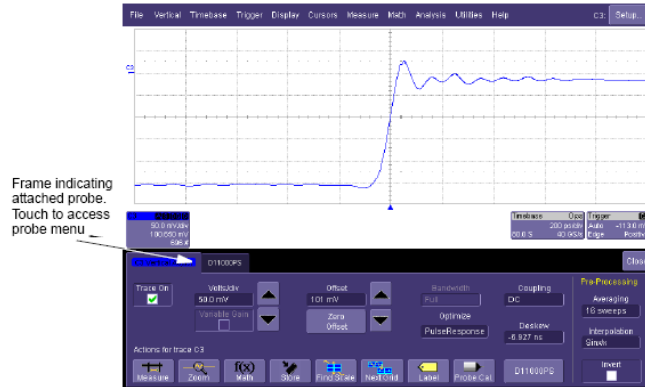

Figure 4. Vertical Menu

When the probe's output connector is attached to the SDA 13000/SDA 11000 oscilloscope's input connector, the oscilloscope will recognize the probe and activate the vertical channel functions in the user interface. Refer to your oscilloscope's instruction manual for operations of the oscilloscope.

Control through the oscilloscope's interface can be found in the screen menu of the channel to which the probe is connected.

Touching the tab indicating the attached probe (in this case D11000PS) will activate the probe menu screen.

The probe information frame shows the characteristics of the probe only.

In some applications it may be desirable to turn the probe's Auto-Color ID OFF or ON with touching the Led On frame.

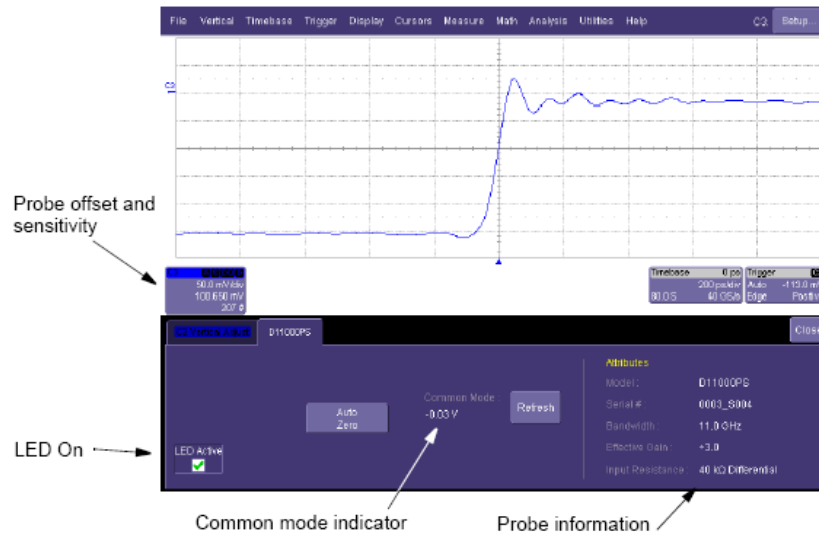

Figure 5. Probe menu.

CONNECTING THE PROBE TO THE TEST CIRCUIT

For all modules and interconnect leads, positive voltages applied to the + input relative to the – input will deflect the oscilloscope trace towards the top of the screen.

To maintain the high frequency capability of the probe in measurement applications, care must be exercised in connecting the probe to the test circuit. Increasing the parasitic capacitance or inductance in the input path may introduce a ring or slow the rise time of fast rising signals. Any extension of the signal path with extra wire leads etc. will adversely affect the performance of the probe.

Generally a ground connection is not required. Refer to section on Probe Grounding later in this chapter.

WAVELINK DIFFERENTIAL PROBE

Solder-In Tip Module

The Solder-In Tip Module is supplied with two pre-installed resistors which are intended to be soldered to the runs or pads test points on the board under test. Because the resistors and the leads are small, this interconnect lead provides the maximum signal fidelity at the highest frequency response.

Use a small solder iron to attach the free wires of the resistors to the appropriate test points.

Note

The primary function of the Probe Tip Retaining Clip is to position the resistor leads when soldering the resistors to the test points.

Caution

Because resistors are small to maintain high frequency performance, they are not sturdy enough to support the weight of the probe module. The module should be supported by other means.

A positioning tool, such as the Tip Retaining Clip should be used at the probe tip (as shown), while the Board Clip or Free-Hand should be used with the probe body.

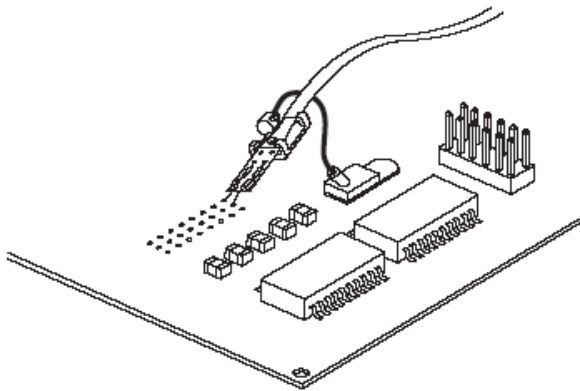

Figure 6. Supporting the Solder-In Tip Module

SMA Tip Module

The SMA Interconnect System has been designed to connect directly to female SMA connectors as well as to the higher performance 3.5 mm and 2.92 mm female connectors.

The Interconnect Lead connects to the Probe Module and the matched pair of SMA Leads connects to the Interconnect Lead.

Note

The SMA leads use the same connectors as in the interconnect leads and will physically mate with the probe tip module. However, the system will not work properly in this configuration. No damage to the probe or amplifier will occur. However, maximum voltage to prevent destruction will be much lower and the susceptibility to ESD is reduced.

Note

The SMA Input Leads are supplied as a matched pair. Individual cables should not be interchanged between probes.

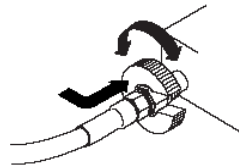

Figure 7. Using the Thumb Wrench

A SMA Finger Wrench is supplied to aid in tightening the SMA connectors.

The SMA connector should be tightened to a torque of 8 in-oz. This finger tight can be approximated when using the wrench.

WAVELINK DIFFERENTIAL PROBE

USE OF DC BLOCKING ADAPTER

The DC Blocking adapter should be used when the common mode voltage of the circuit under test is unknown or exceeds the maximum common mode voltage specified. (See section 9, Specifications)

Connect the each SMA Input Lead to a DC Block and the male side of the DC Block to the SMA connector of the circuit under test.

When the DC blocking adapter is used, the probe is AC coupled and the LF cut-off frequency is approximately 10 MHz.

Note

When using the DC Blocking Adapter set the Serial Data Analyzer's OFFSET to zero.

POSITIONING OF THE INPUT LEADS

Normally, the performance of the Solder In module is not affected by the position of the modules. They can be mounted straight up or under an angle. However when it is necessary to mount the module parallel to the board, the maximum performance is obtained when the '+' sign, printed near the positive input of the module, is facing up and the ground plane on the opposite side of the module's input is facing the board. The flexible cable connecting the input tip to the module is insensitive to placement.

POSITIONING TOOLS

To support the probe and module and to reduce the risk of damaging runs or pads on the board, always use positioning tools as probe support.

Tip Retaining Clip

The Probe Tip Retaining Clip has been designed to give support to the probe when soldering the resistors of the Solder-In module to test points.

To fasten the clip to the board, remove the small piece of protection paper from one side of the adhesive pad and mount the pad to the underside of the clip. If necessary clean the section of the grease or flux residue.

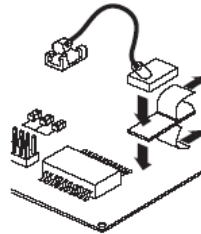

Figure 8. Connecting the SI Module Using the Tip Retaining Clip

Remove the protective paper from the other side of the adhesive pad and mount the clip to the desired location on the board. Apply pressure to the clip for at least several seconds to assure proper adhesion.

The adhesive pad with the tab will still be visible and stays attached to the adhesive pad. The tab will be used to remove the clip from the board.

Note

Maximum strength of the adhesive pad is obtained after about 30 min.

If you have to bend the arms to move the probe adapter part of the clip for positioning or attaching the probe before the adhesive has cured properly, always apply pressure to the pad to prevent the pad from shifting.

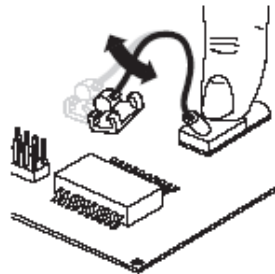

Figure 9. Apply pressure when adjusting the probe holder.

WAVELINK DIFFERENTIAL PROBE

Attaching the Probe

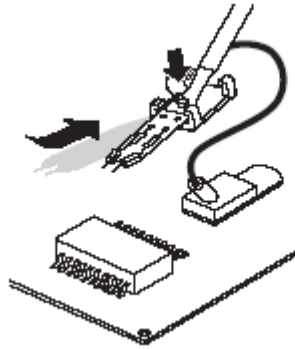

Figure 10. Attaching the Probe.

To attach the probe, position the cable of the module on top of the clip and slide the input board of the module into the grooves. While moving the probe into position for measurement, apply pressure to the mounting pad to prevent the adhesive pad from moving and losing its adhesion.

Tip Retaining Clip Removal

To remove the Retaining Clip from the board, pull on the tab of the adhesive pad. The clip can now be removed easily without leaving any adhesive residue and can be used in another application using a new adhesive pad.

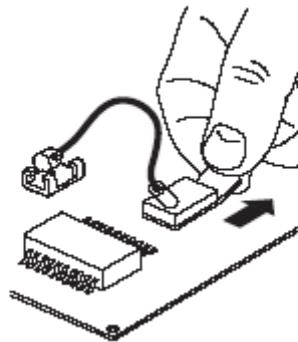

Figure 11. Removing the Retaining Clip.

Probe Body Location Clip

The Probe Body Location Clip can be used to give support to the probe and Interconnect Lead when the test points are located close to the edge of the board under test. Slide the probe cable into the clamp opening and move the probe so that the probe's strain relief is located in the opening. Close the clamp.

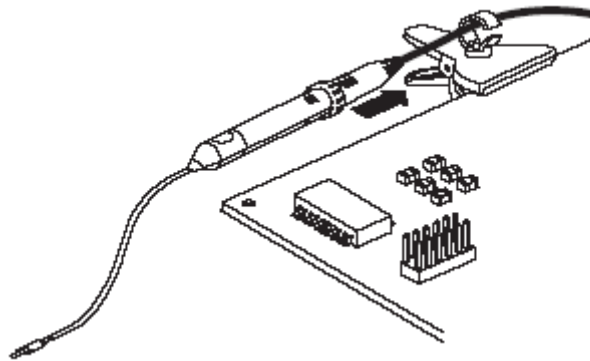

Figure 12. Slide Probe into Board Clip

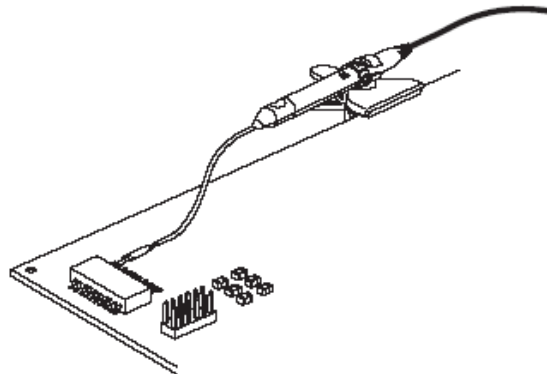

Figure 13. Probe Body Location Clip

WAVELINK DIFFERENTIAL PROBE

FreeHand Probe Holder

The FreeHand Probe Holder, PACC-MS001, provides a quick, stable, and easily set up probe positioner which can be used to hold the probe when the Clip can not be used.

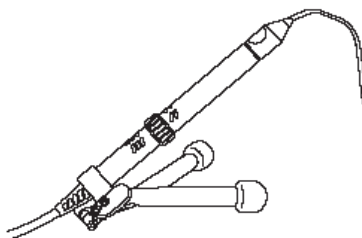

Figure 14. FreeHand Probe Holder

PROBE GROUNDING

In most cases, when the common mode portion of the signal consists mainly of lower frequencies, the probe does not need to be connected to ground of the circuit under test. This will minimize the effects of ground loop currents. Any signal corruption caused by not having the probe connected to ground of the signal under test will be common to both inputs and will be rejected by the differential operation of the probe.

However, when working in an environment with high RF ambient noise, it may be better to connect the probe ground lead to a good RF ground near the point where the signal is being measured. To find out if a ground lead is necessary, make a measurement with and without a ground lead and use the one that gives the least signal corruption.

Capacitive coupling from AC mains may cause truly floating devices, like battery operated devices, to exceed the common mode range. In such cases it is recommended to connect the probe ground to the device under test.

CAUTION



Always use a ground lead when testing floating circuits.

Floating circuitry may exceed the common mode input voltage causing damage the probe.

Example: Circuits powered from laboratory bench power supplies which normally have floating outputs.

OFFSET

Offset for the D13000PS/D11000PS probe system is provided by LeCroy's SDA 13000/11000 Serial data analyzer. This allows you to remove a DC bias voltage from the input signal while maintaining DC coupling. To prevent displaying a clipped waveform from overdriving the probe, the available offset changes as a function of the V/Div setting of the oscilloscope.

The following equation determines the available offset as a function of oscilloscope sensitivity:

$$\text{MaximumOffset} = \pm V - 4x \text{ V/div}$$

where

V is the maximum range of the probe, 1 V, and V/div is the selected scale factor.

As can be seen the maximum offset for the probe is 4 V, while the minimum offset is 0 Volt.

The probe offset is controlled with the SDA 13000/11000's OFFSET knob.

Note

The OFFSET should remain at zero when using the DCBlocking adapters.

DYNAMIC RANGE

The D13000PS/D11000PS probe has no gain or attenuation control. The system attenuation is fixed at $\times 3$.

The D13000PS/D11000PS probe is always DC coupled, no internal AC coupling is provided, thus care must be exercised to avoid exceeding the common mode range. Exceeding the common mode range may introduce distortion to the probe's output signal.

The use of the DC Blocking Adapter with the SMA tip is strongly recommended in applications where the common mode voltage is unknown or exceeds the specified maximum.

There are two common mode voltages:

± 4 volt for the Solder-In tip and

± 2 volt for the SMA tip.

BLANK PAGE

CARE AND MAINTENANCE

CLEANING

The exterior of the probe and cable should be cleaned using a soft cloth only moistened with water or isopropyl alcohol. The use of abrasive agents, strong detergents or other solvents may damage the exterior of the probe.



CAUTION

The probe case is not sealed and should never be immersed in any fluid.

SERVICE STRATEGY

Defective probes or probe tip modules must be returned to a LeCroy service facility for diagnosis and repair or replacement. A defective product under warranty will be repaired or replaced.

RETURNING A PROBE FOR CALIBRATION OR SERVICE

The procedure for returning a product for calibration or service: Contact your local LeCroy sales representative to find out where to return the product. All returned products should be identified by model number and serial number. Provide your name and contact number and if possible describe the defect or failure. In case of products returned to the factory, a Return Authorization Number (RAN) should be used. The RAN can be established by contacting your nearest LeCroy sales office, representative, or the North America Customer Care Center.

Return shipment should be prepaid. LeCroy cannot accept COD or Collect Return shipments. Air-freight is recommended.

Note

It is important that the RAN be clearly shown on the outside of the shipping package for prompt redirection to the appropriate department.

1. Contact your local LeCroy sales or service representative to obtain a Return Authorization Number.
2. Remove all accessories from the probe. Do not include the manual. If you need to return a D13000PS/D11000PS system, do include all Interconnect Leads.

WAVELINK DIFFERENTIAL PROBE

3. Pack the probe in its case, surrounded by the original packing material (or equivalent) and box.
4. Label the case with a tag containing:
 - The RAN
 - Name and address of the owner
 - Product model and serial number
 - Description of failure
5. Package the probe case in a cardboard shipping box with adequate padding to avoid damage in transit.
6. Mark the outside of the box with the shipping address given to you by the LeCroy representative; be sure to add the following:
 - ATTN: <RAN assigned by the LeCroy representative>
 - FRAGILE
7. Insure the item for the replacement cost of the product.
8. Ship the package to the appropriate address.

RETURNING A PROBE TO A DIFFERENT COUNTRY

In order to avoid customs duty for purchase price of a new probe or accessory, when your probe is returned for service, please use the following procedure.

In addition to the items mentioned above in 'Returning a probe for calibration or service', you'll need to mark shipments returned for service as a 'Return of US manufactured goods for warranty repair/recalibration'. If there is a cost involved in the service, put the cost of the service in the value column and the original value of the product at time of purchase in the body of the invoice marked 'For insurance purposes only'. Be very specific as to the reason for shipment. Duties may have to be paid on the value of the service.

REPLACEMENT PARTS

The probe accessories and other common parts can be ordered through the regional customer care centers. Refer to the following table for LeCroy part numbers.

Item	LeCroy P/N	Replacement Quantity
Solder-In Interconnect Lead	D11000PS	1
Ground Lead	PACC-LD005	1
Ground Clip	PK006-4	1
Tip Retaining Clip for Solder-In Lead	PK600ST-3	1
SMA DC Blocking Adapters		1
Probe Body Clamp Set	PK600ST-4	1
FreeHand Probe Holder	PACC-MS001	1
Soft Accessory Case	SAC-01	1
D13000PS/D11000PS Instruction Manual	DPS-OM-E Rev A	1

Table 1. Replaceable Parts List

WAVELINK DIFFERENTIAL PROBE

BLANK PAGE

REFERENCE INFORMATION

PROBE INPUT LOADING

Attaching any probe to a test circuit will add some loading to the circuit under test. In most applications the high impedance of the probe, compared to the impedance of the circuit under test, will impart an insignificant load to the test circuit. However at very high frequencies the capacitive reactance of the Solder-In Interconnect Lead may load the circuit enough to affect the measurement. This probe is designed to minimize these effects at high frequencies. Refer to the next two Figures for equivalent input circuit information.

These circuits represent the aggregate load placed on the test circuit, but not the actual input circuit of the probe. For critical applications, you can enter the information of your module or lead into SPICE to accurately represent the probe loading.

Note

*To avoid degrading the high frequency performance of the probe, **do not** extend the input pins on the module.*

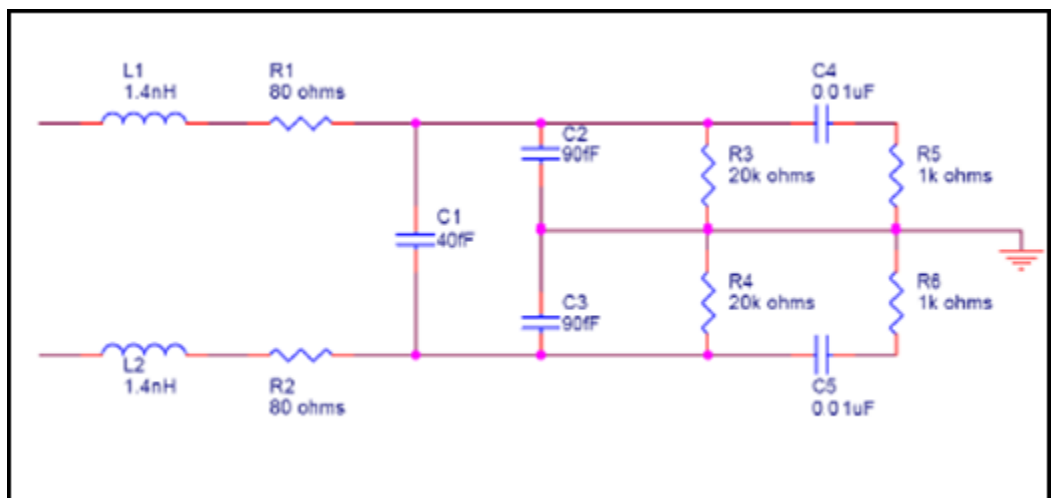

Figure 15. D13000PS Solder-In Lead Equivalent Input Circuit

WAVELINK DIFFERENTIAL PROBE

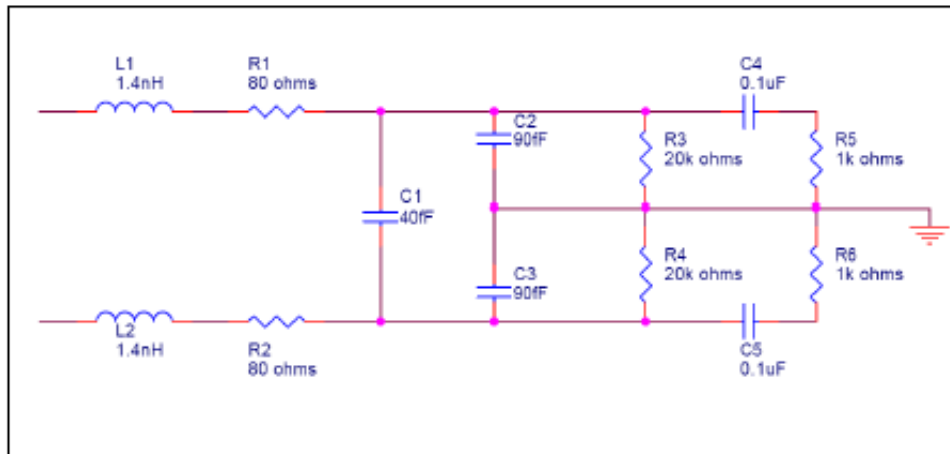

Figure 16. D11000PS Solder-In Lead Equivalent Input Circuit

DIFFERENTIAL MODE AND COMMON MODE

Differential probes sense the voltage difference which appears between the + input and – input. This voltage is referred to as the Differential Mode or Normal Mode voltage. The voltage component which is referenced to earth and is identical on both inputs is rejected by the amplifier. This voltage is referred to as the Common Mode voltage and can be expressed as:

$$V_{CM} = \frac{V_{+input} + V_{-input}}{2}$$

DIFFERENTIAL MODE RANGE AND COMMON MODE RANGE

Differential Mode range is the maximum signal which can be applied between the + and – inputs without overloading the probe/amplifier, which otherwise would result in clipping or distorting the waveform measured by the oscilloscope.

The Common Mode Range is the maximum voltage with respect to earth ground which can be applied to either input. Exceeding the common mode range can result in unpredictable measurements. Because the Common Mode signal is normally rejected and not displayed on the oscilloscope, the user needs to be careful to avoid accidentally exceeding the common mode range.

COMMON MODE REJECTION RATIO

The ideal differential probe/amplifier would sense and amplify only the differential mode voltage component and reject the entire common mode voltage component. Real differential amplifiers are not perfect and a small portion of the common mode voltage component appears at the output. Common Mode Rejection Ratio (CMRR) is the measure of how much the amplifier rejects the common mode voltage component. CMRR is equal to the differential mode gain (or normal gain) divided by the common mode gain. Common mode gain is equal to the output voltage divided by the input voltage when both inputs are driven by only the common mode signal. CMRR can be expressed as a ratio (e.g. 10 000:1) or implicitly in dB (e.g. 80 dB). Higher numbers indicate greater rejection (better performance).

The first order term which determines the CMRR is the relative gain matching between the + and – input paths. To obtain high CMRR values, the input attenuators in a differential amplifier are precisely matched to each other. The matching includes the DC attenuation as well as the capacitance which determines the AC attenuation. As the frequency of the common mode component increases, the effects of stray parasitic capacitance and inductance in determining the AC component becomes more pronounced. The CMRR becomes smaller as the frequency increases. Hence the CMRR is usually specified in a graph of CMRR versus common mode frequency.

The common mode frequency in these graphs is assumed to be sinusoidal. In real life applications, the common mode signal is seldom a pure sine wave. Signals with pulse wave shapes contain frequency components much higher than the repetition rate may suggest. As such, it is very difficult to predict actual performance in the application for CMRR versus frequency graphs. The practical application of these graphs is to compare the relative common mode rejection performance between different probes and amplifiers.

WAVELINK DIFFERENTIAL PROBE

FUNCTIONAL TEST

INTRODUCTION

The functional test can be used to verify the basic operation of the D13000PS/D11000PS probe system functions using a LeCroy SDA 13000/11000 Serial Data Analyzer. Refer to the oscilloscope's Instruction Manual for proper use of the touch screen and controls.

TEST

Perform basic setup tests as follows:

1. Connect the probe to channel 1 of the SDA 13000/11000. The instant the probe is connected to the oscilloscope, the Auto-Color ID LEDs should illuminate GREEN for less than 1 second.

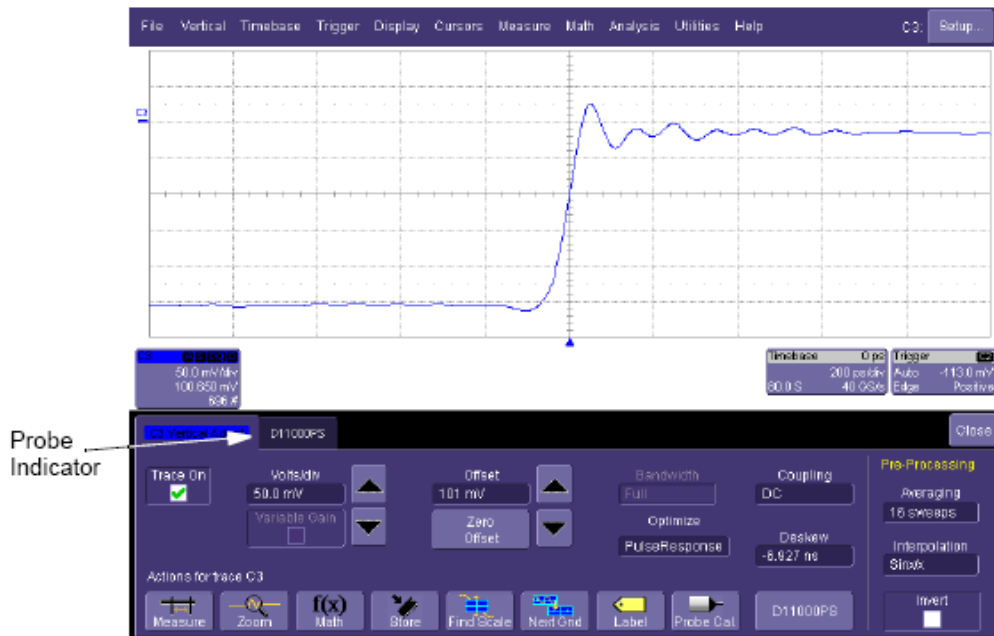

Figure 17. Vertical Channel setup.

2. After the green indication, the Probe's AutoColor ID indicators will illuminate in the color of the channel to which the probe is connected. Disconnect the probe and reconnect to the other channels to verify that the probe's AutoColor ID in each case indicates proper channel. Reconnect probe to Channel 3.
3. Turn on the channel to which the probe is connected.
4. Touch the Ch 3 (channel to which the probe is connected) frame on the touch screen. Verify that probe model, in this case D11000PS, is shown on the screen menu.
5. Touch D11000PS/D13000PS frame to bring up the probe's menu.

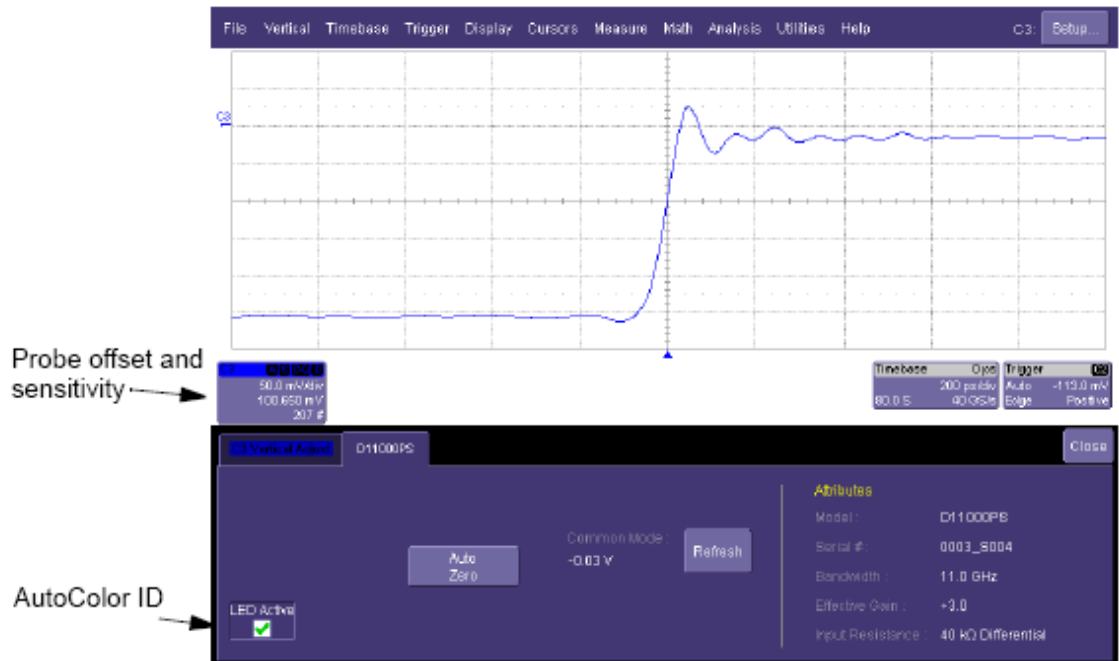

Figure 18. D11000PS probe menu.

6. Touch Led Active frame to verify that the probe's AutoColor ID LEDs turn off (probe power is still ON). Turn LEDs back ON.

WAVELINK DIFFERENTIAL PROBE

7. To perform the functional tests the Calibrator needs to be set up first. Press the UTILITIES button on the oscilloscope's front panel.
8. Touch the Utilities frame on top of the screen and select Aux Output on the touch screen menu on the bottom of the screen (see the following figure).
9. Touch the Auxiliary output setting frame to obtain a square wave output signal.

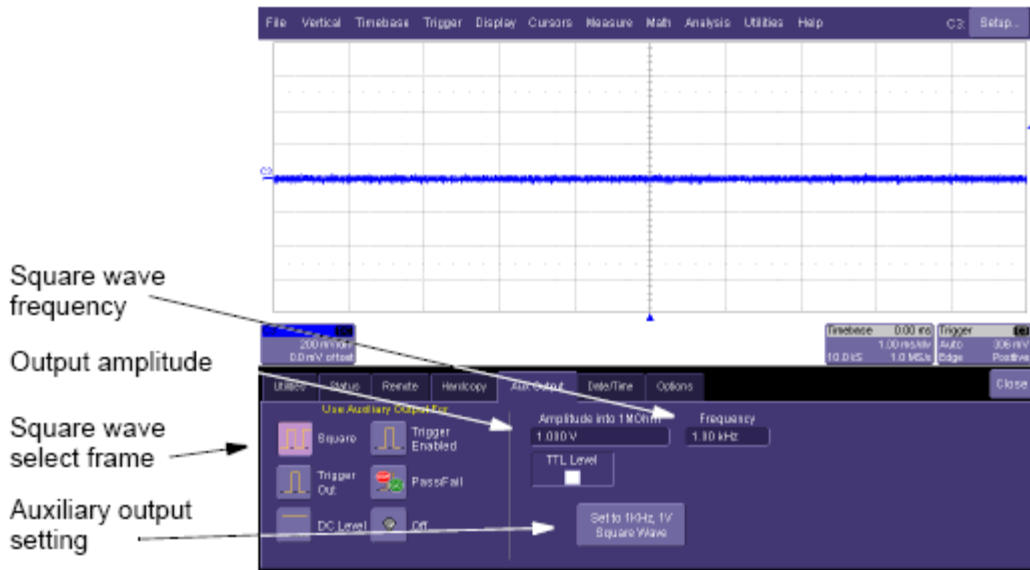

Figure 19. Auxiliary output setup.

10. Set the amplitude to 1 Volt, Frequency to 1.00 kHz, Offset to 0 V.
11. Verify that screen indicates the proper setting in the Auxiliary Output settings frame.
12. Set the probe sensitivity to 200 mV/div.
13. For the Solder-In Tip connect the + tip to the center conductor of the calibrator output signal, and the – pin to the shell (ground) of the connector. Readjust tip spacing if necessary.

For the SMA Tip connect a male BNC to female SMA adapter to the Auxiliary Output and connect the + SMA Tip to the adapter.

14. Verify that the screen shows a square wave of about 2.5 divisions. Refer to the following figure. If no square wave is shown, the + channel of the probe may be faulty.

Note

Only a 2.5 division signal will be shown, since the 50 Ω Auxiliary output and the 50 Ω input of the SMA tip causes the signal to be divided by 2.



Figure 20. Square wave output signal.

15. To obtain a stable display press AUTO SETUP on the oscilloscope's front panel.
16. For the Solder-In Tip, adjust so both tips touch or almost touch.
17. Connect both tips to the calibrator output signal center conductor.
18. Verify that a straight line is shown, centered on screen. There should not be any vertical deflection to indicate good CMRR.
19. One of the channels may be at fault if a square wave or part of a square wave is shown.

This concludes the functional tests of the D13000PS/D11000PS Differential Probe.

BLANK PAGE

PERFORMANCE VERIFICATION

INTRODUCTION

This procedure can be used to verify the warranted characteristics of the D13000PS/D11000PS Probe System.

The recommended calibration interval for this differential probe system is one year. Test results can be recorded on a photocopy of the Test Record provided in Appendix A.

Performance Verification can be completed without removing the probe covers or exposing the user to hazardous voltages.

No adjustments are provided.

In the unlikely event that a probe should fail the performance verification, it can be sent back to the local service center or the factory. For information on returning the probe refer to Section 5, Care and Maintenance.

This procedure tests the D13000PS/D11000PS for the following warranted specifications:

- Output Zero
- Low frequency attenuation accuracy
- Rise time (SMA tip only)

The specified parameters apply to the probe tip module and the accompanying probe body.

Note

It is recommended that the Functional Check be performed prior to the Performance Verification Procedure to assure that all other non-warranted functions perform as specified. For the Functional check refer to Section 7, Functional Test.

WAVELINK DIFFERENTIAL PROBE

TEST EQUIPMENT REQUIRED

The following table lists the test equipment and accessories, or their equivalents that are required for performance verification of the D13000PS/D11000PS Differential Probe System.

This procedure has been developed to minimize the number of parameters required to be calibrated in the test instrumentation.

Only the parameters listed in boldface in the “Minimum Requirements” column must be calibrated to the accuracy indicated.

Because the input and output connector types may vary on different brands and models of test instruments, additional adapters or cables may be required.

OPERATOR'S MANUAL

Description	Minimum Requirements	Test Equipment Examples
Oscilloscope, High BW	SDA 13000/SDA 11000	LeCroy: SDA 13000/SDA 11000
Digital Multimeter	AC: 0.2% accuracy to measure 200 mV and 2 V rms @ 1 kHz 6½ digit resolution	Agilent Technologies: 34401A, or Fluke: 8842A-09, or Keithley: 2001
Oscillator/Function Generator	Sine Wave output, adjustable from 500 mV to 4 Vp-p (357 mV to 2.83 Vrms) at 70 Hz	Stanford Research: Model DS340, or Agilent Technologies: 33120A, or Leader: LAG-120B
Pulse Generator	12 psec, -5 V _{out} , 2.4 mm output	Picosecond Pulse Labs: 4015D-215
Calibration Fixture		LeCroy: ProLink-CF01
ProLink Adapter		LeCroy: LPA-SMA
Terminator, Precision, BNC	50 Ω ± 0.05%	LeCroy: TERM-CF01
SMA to BNC Adapter	Female SMA to male BNC	Pomona Electronics: 4289 Pasternack Enterprises: PE9073
SMA to BNC Adapter	Female SMA to female BNC	Pomona Electronics: 4291 Pasternack Enterprises: PE9075
Terminator, SMA	Female SMA, 50 Ω, ½ W	Pomona Electronics: 4287 Pasternack Enterprises: PE6003
Attenuator	Male SMA to female SMA, 50 Ω, 20 dB, 18 GHz	Pasternack Enterprises: PE7005-20
BNC coaxial cable, (3 ea)	Male-male BNC, 50 Ω, 36"	Pomona Electronics: 2249-C-36 Pasternack Enterprises: PE3067-36
SMA coaxial cable	Male-male SMA, 50 Ω, 36"	Pomona Electronics: 4846-K-24 Pasternack Enterprises: PE3369-36
BNC Tee adapter	Male to dual female, BNC	Pomona Electronics: 3285 Pasternack Enterprises: PE9001
BNC Adapter	Female BNC to female BNC	Pomona Electronics: 3283 Pasternack Enterprises: PE9084
Banana Plug adapter	Female BNC to dual banana plug	Pomona Electronics: 1269 Pasternack Enterprises: PE9008
Adapter	Female 2.4 mm to female SMA	Pasternack Enterprises: PE9656
SMA Finger Wrench	For tightening SMA connectors	(Included with D11000PS)
BNC to Minigrabber Test Clip	Female BNC to mini-grabber	Pomona: 5188
Keyboard	USB interface	
Mouse	USB interface	

Table 2. List of Required Equipment.

WAVELINK DIFFERENTIAL PROBE

PRELIMINARY PROCEDURE

1. Connect the D13000PS/D11000PS to the input of ProLink-CF01 Calibration Fixture.
Remove the captive screws from the ProLink-CF01 to allow the D13000PS/D11000PS to connect to the Calibration Fixture.
2. Connect the output of the ProLink-CF01 Calibration Fixture to Channel 2 of the SDA13000/11000.
3. Allow at least 20 minutes warm-up time for the WaveLink probe and test equipment before performing the Verification Procedure.
4. Turn on the other test equipment and allow these to warm up for the time recommended by the manufacturer.
5. While the instruments are reaching operating temperature, make a photocopy of the Performance Verification Test Record (located in Appendix A), and fill in the necessary data.

Most of the warranted characteristics of the D13000PS/D11000PS Differential Probe are valid at any temperature within the Environmental Characteristics listed in Section 9. However, some of the other test equipment used to verify the performance may have environmental limitations required to meet the accuracy requirements needed for the procedure. Be sure that the ambient conditions meet the requirements of all the test instruments used in the procedure.

As specified, the low frequency attenuation accuracy is valid at a reduced temperature range from 20 to 30 °C, verification therefore must be done at an ambient temperature within that range.

VERIFICATION PROCEDURE

This verification procedure describes the tests using a probe with a Solder-In module. The procedure for testing a SMA/SMP module is identical to testing a Solder-In module. *However the connection to the signal generator may be different.*

Actual Probe Attenuation

As part of the Performance Verification Procedure, the actual attenuation of the probe needs to be known. During calibration of the probe, the actual attenuation is programmed into the EEPROM which the oscilloscope reads to set the actual adjustment for the correct Volt/div referenced to the probe input.

The actual probe attenuation can be determined by using LeCroy's ScopeExplorer program which needs to be installed into the test oscilloscope.

This can be done two ways. If the test oscilloscope has access to the internet through a LAN connection, the program can be downloaded directly from:

[LeCroy.com/ServiceSupport/SoftwareDownloads/Oscilloscopes/Software Utilities](http://LeCroy.com/ServiceSupport/SoftwareDownloads/Oscilloscopes/SoftwareUtilities)
and select ScopeExplorer Download. (Approx. 5.1 MB file).

An alternate method is to download the software on another computer and transferring it, either by making a copy on a CD-ROM, or using a USB flash memory key to transfer the file:

[LeCroy.com/ServiceSupport/SoftwareDownloads/Oscilloscopes/Software Utilities](http://LeCroy.com/ServiceSupport/SoftwareDownloads/Oscilloscopes/SoftwareUtilities)
and select ScopeExplorer Download.(Approx. 5.1 MB file) to the test oscilloscope.

After downloading and installing the program in the Serial Data Analyzer, reboot the oscilloscope.

When rebooted, to run ScopeExplorer touch 'File' (top left corner) on the oscilloscope screen and touch 'Minimize' on the newly displayed frame.

- a. On the Windows screen touch 'Start' and touch 'ScopeExplorer' to start ScopeExplorer program.
- b. On the ScopeExplorer frame touch 'Scope' icon located in top left corner.

WAVELINK DIFFERENTIAL PROBE

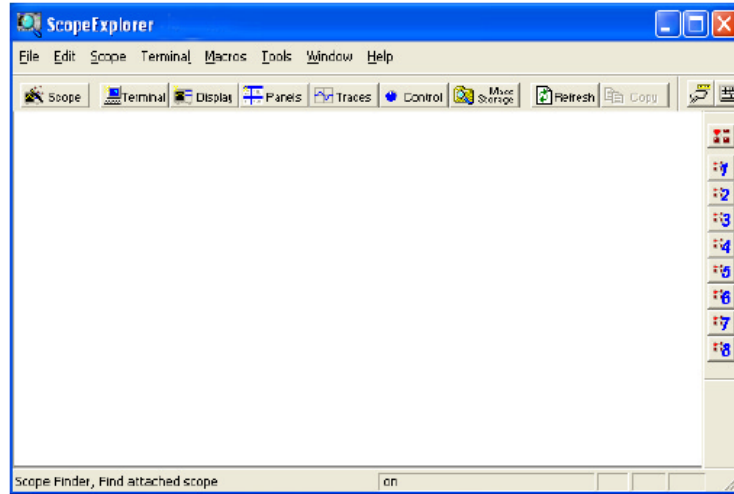

Figure 21. ScopeExplorer

c. In the Scope Selector frame touch 'Add'.

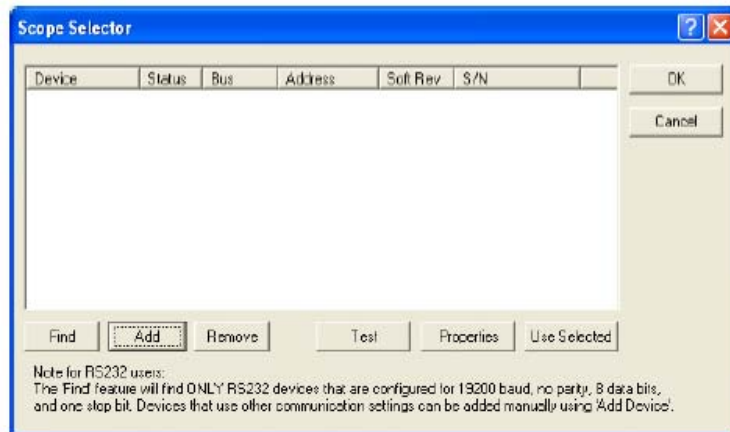

Figure 22. Scope Selector

d. Touch 'Network' in the Add Device frame.

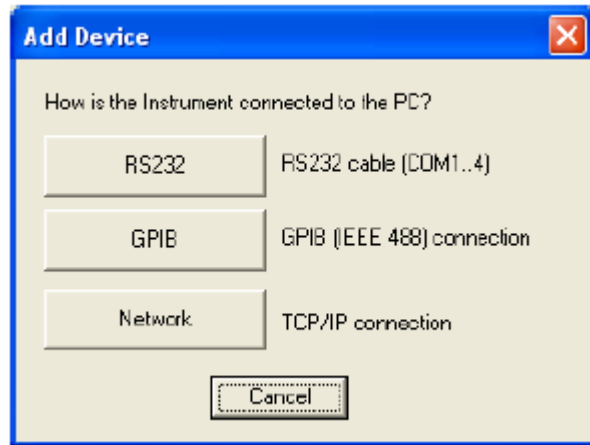

Figure 23. Add Device

- e. Enter the loop back address: 127.0.0.1 in the 'Network Device' frame and touch OK.

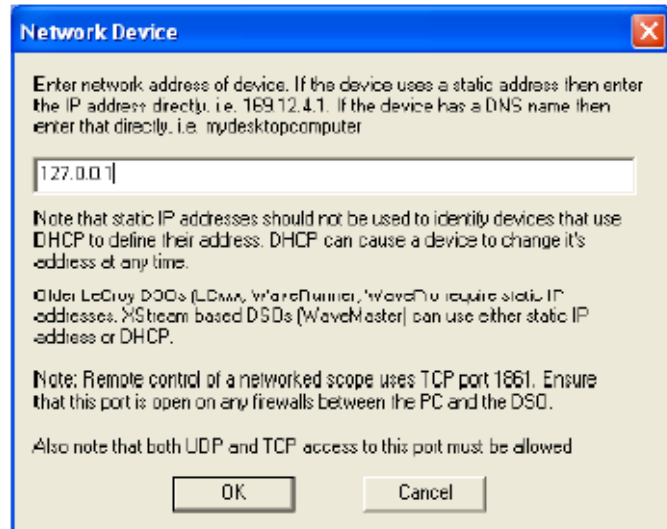

Figure 24. Entering Loop Back Address

WAVELINK DIFFERENTIAL PROBE

- f. Highlight the new device in the Scope Selector frame and touch 'Test' to confirm you have a successful connection to the oscilloscope application.
- g. Touch OK until you are returned to the ScopeExplorer frame.
- h. Touch 'Terminal' and enter the query:
`vbs? `return=app.acquisition.c2.
d11000ps.prattenuation``
Where c2 denotes channel 2, the channel to which the probe is connected. If the probe is a D13000PS, then the query should be:
`vbs? `return=app.acquisition.c2.
d13000ps.prattenuation``
- i. Click 'Return'.

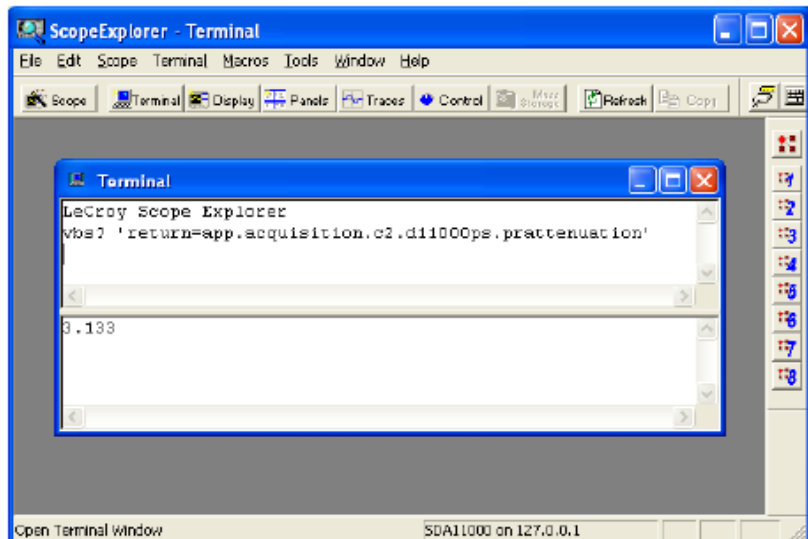

Figure 25. ScopeExplorer Query Response.

- j. You will see the actual probe attenuation number at the bottom part of the Terminal window.
- k. Record this number as 'Actual Probe Attenuation' in the Test Record.

Note

The Actual Probe Attenuation number will be used in the Output Zero and Attenuation Accuracy tests.

Output Zero

- a. To measure the output signal of the probe, connect the ProLink-CF01 to Channel 2 of a SDA 13000/SDA 11000 Serial data Analyzer.

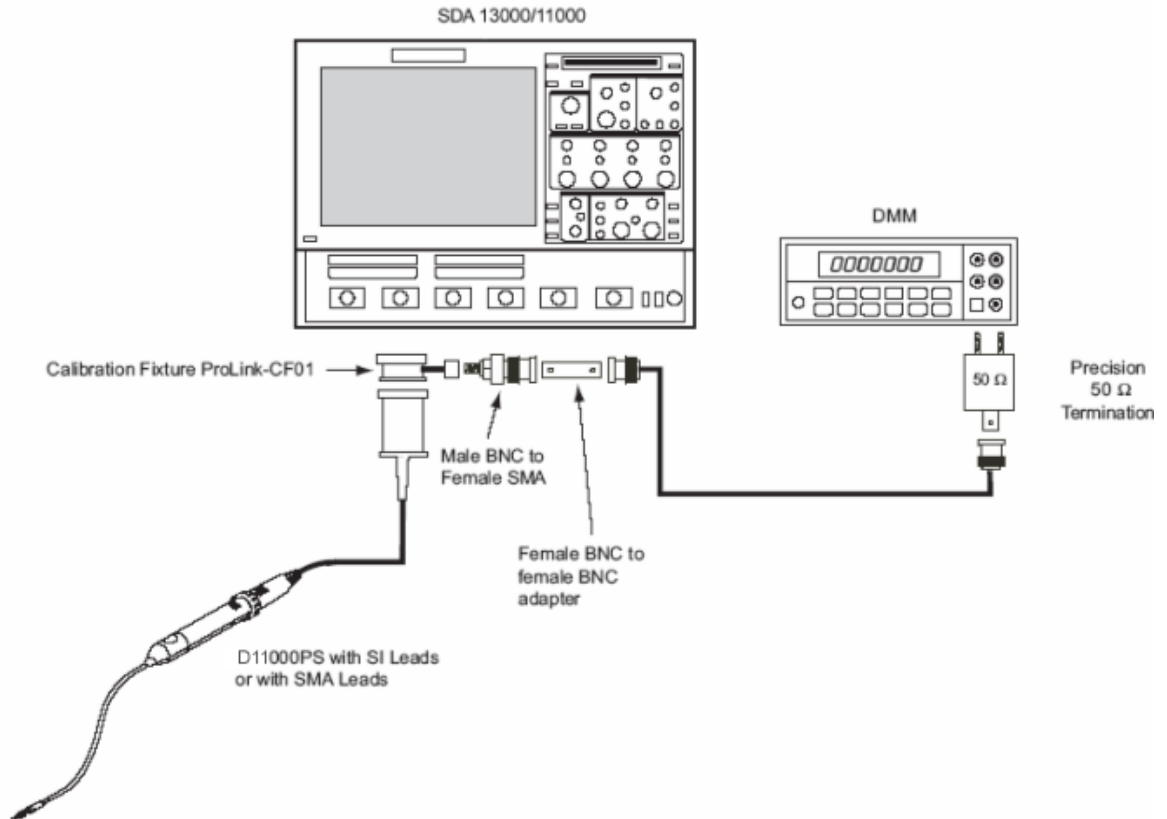

Figure 26. Output Zero Voltage

- b. Connect a BNC to SMA adapter to the SMA output connector of the ProLink-CF01 Calibration Fixture and the BNC end to a female BNC to female BNC adapter.
- c. Connect the Precision 50 Ω Terminator via a BNC cable to the free end of the BNC to BNC adapter.
- d. Set the DMM to DC volt.
- e. Connect the Precision 50 Ω Terminator to the DMM input.

WAVELINK DIFFERENTIAL PROBE

- f. After a warmup time of at least 20 minutes, measure the output voltage and record the result to 1 mV resolution as 'Output Voltage' in the Test Record.
- g. Initiate an AutoZero.
- h. Wait an additional 20 minutes, then record the DMM reading to 1 mV resolution in the Test Record as 'Output Voltage after AutoZero'.
- i. Take the difference of the two readings recorded in 2-f and 2-h and multiply by the number recorded in step 1-k.
- j. Record the result as 'Output Zero' in the Test Record.
- k. Check that the absolute value of Output Zero is less than 15 mV.

Attenuation Accuracy

- a. Connect the male end of a BNC Tee to the Sine Wave Generator output. Refer to the following Figure for setup information. Set the generator's output voltage to 0 Volt.
- b. Connect a BNC cable to one end of the BNC Tee and the other end of the cable to the female BNC to Dual Banana Plug Adapter.
- c. Connect the Banana Plug Adapter to the DMM input, verifying that the ground side of the adapter is connected to the low side of the DMM.
- d. Connect another BNC cable to the free end of the BNC Tee.
- e. When testing a Solder-In module, connect a BNC to mini grabber test clips to the free end of a BNC cable.
When testing a SMA module connect a female BNC to female SMA adapter to the free end of the BNC cable.

CAUTION



Be careful attaching the mini-grabber clips to the Solder-In Tipleads. These leads are strong but can break off with excessive force. To prevent any stress on the Solder-In leads it is recommended to restrain both the Solder-In tip board and the Mini-Grabber.

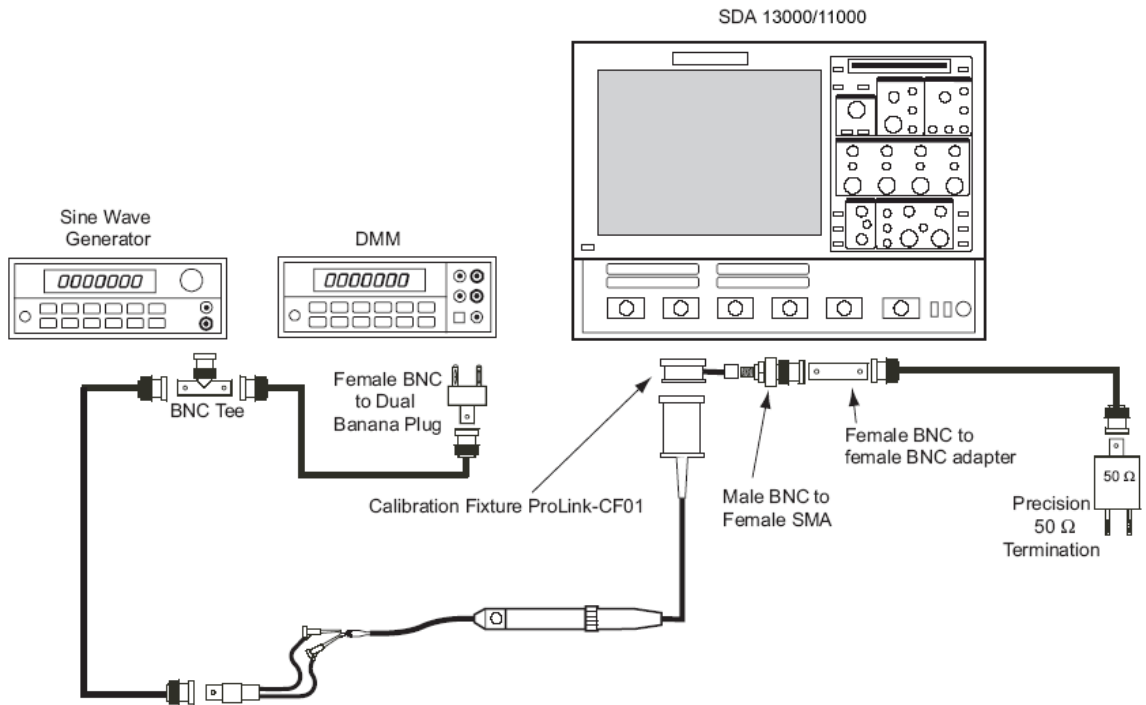

Figure 27. Measuring Input Voltage of D13000PS/D11000PS.

- f. Attach a ProLink-CF01 Calibration Fixture to the output of the D13000PS/D11000PS.
Remove the captive screws from the ProLink-CF01 to allow the D13000PS/D11000PS to connect to the Calibration Fixture.
- g. Connect the Calibration Fixture to Channel 2 of the Serial Data Analyzer SDA 13000/SDA 11000.
- h. Connect a male BNC to female SMA adapter to the SMA output connector of the ProLink-CF01 Calibration Fixture and the BNC end to a female to female BNC adapter.
- i. Connect the Precision 50 Ω Terminator via another BNC cable to the free end of the female to female BNC adapter.
- j. Leave the unused end of the Precision Terminator floating for the time being.
- k. Set the DMM to read AC.

WAVELINK DIFFERENTIAL PROBE

- I. When testing the Solder-In tip, connect the red mini-grabber lead to the + side of the SI tip and the black grabber lead to the – side of the SI tip.

For the SMA tip, connect the + SMA input to a female BNC to female SMA adapter and connect a 50 Ω SMA terminator to the – SMA input.

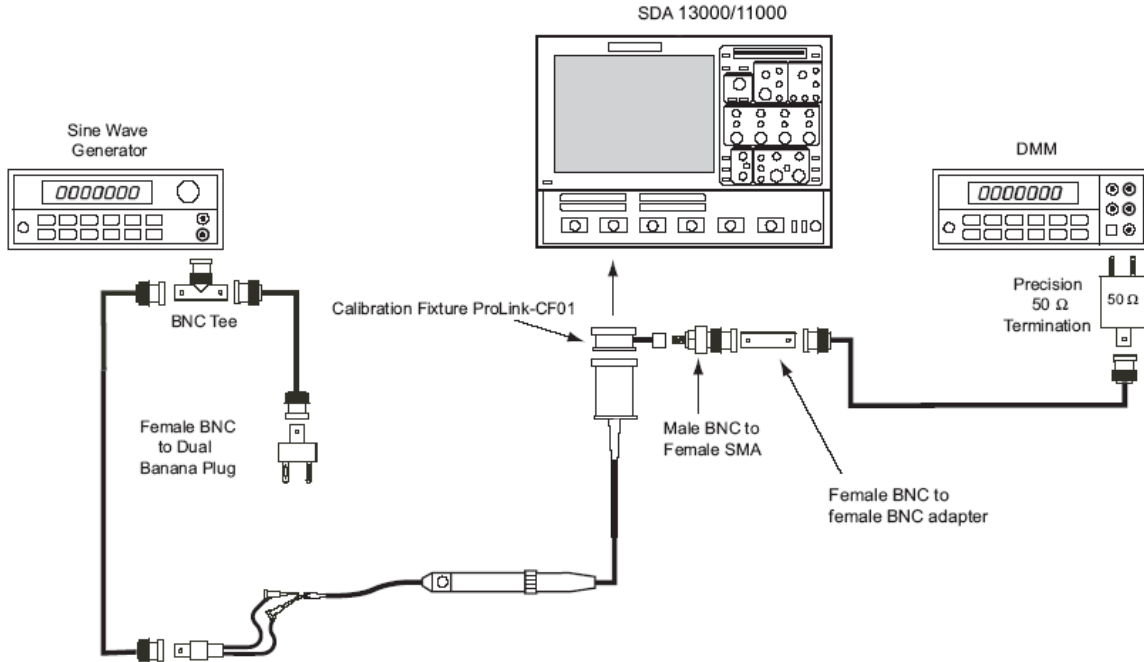

Figure 28. Measuring Output Voltage of D13000PS/D11000PS.



CAUTION

Be careful attaching the mini-grabber clips to the Solder-In Tipleads. These leads are strong, but can break off with excessive force.

- m. Set the sine wave generator to about 70 Hz and the output to 1.5 Vp-p (0.530 Vrms) as indicated on the DMM.
- n. Record the DMM reading to 1 mV resolution in the Test Record as 'Input Voltage'.
- o. Unplug the BNC to Banana Plug Adapter from the DMM and connect the Precision 50 Ω Terminator to the DMM input.

- p. After the DMM has stabilized, record the reading to 1 mV resolution as 'Output Voltage' in the Test Record.
- q. To take the probe's attenuation into account, multiply the reading recorded in step 3-p by the number recorded in step 1-k. Record the result as 'Corrected Output Voltage' in the Test Record.
- r. Divide the output voltage obtained in step 3-q by the input voltage obtained in step 3-n. Subtract the ratio from 1.0 and multiply the result by 100% to get the error in percent.

$$Error = \left(1 - \frac{Corrected\ Probe\ Output\ Voltage}{Probe\ Input\ Voltage}\right) \times 100\%$$

- s. Record the result to two decimal places ($\pm 0.xx\%$) as 'Attenuation Error' in the Test Record.
- t. Check that the calculated Low Voltage Attenuation Error is less than $\pm 2\%$.
- u. Leave the set up as is for the next step.

Rise Time (10% to 90%)

Measuring the probe's rise time cannot be done directly; it has to be performed in an indirect way. First you have to measure the rise time of the total system i.e. rise time of the pulse generator and the oscilloscope. Second, measure the rise time of the probe's output. The rise time of the probe alone can then be determined from these two measurements.

This section will test the rise times for:

SMA Interconnect Lead with the matched pair SMA/SMP Input Cables.

Note

Only the D13000PS/D11000PS with SMA/SMP Interconnect Lead with the matched pair of SMA Input Cables has a warranted rise time and needs to be verified.

- a. Connect the LPA-SMA adapter to Channel 2 of the oscilloscope.
- b. Connect a 20 dB SMA attenuator via a female 2.4 mm to female SMA adapter to the output of the pulse generator's pulse head.

WAVELINK DIFFERENTIAL PROBE

SDA 13000/11000

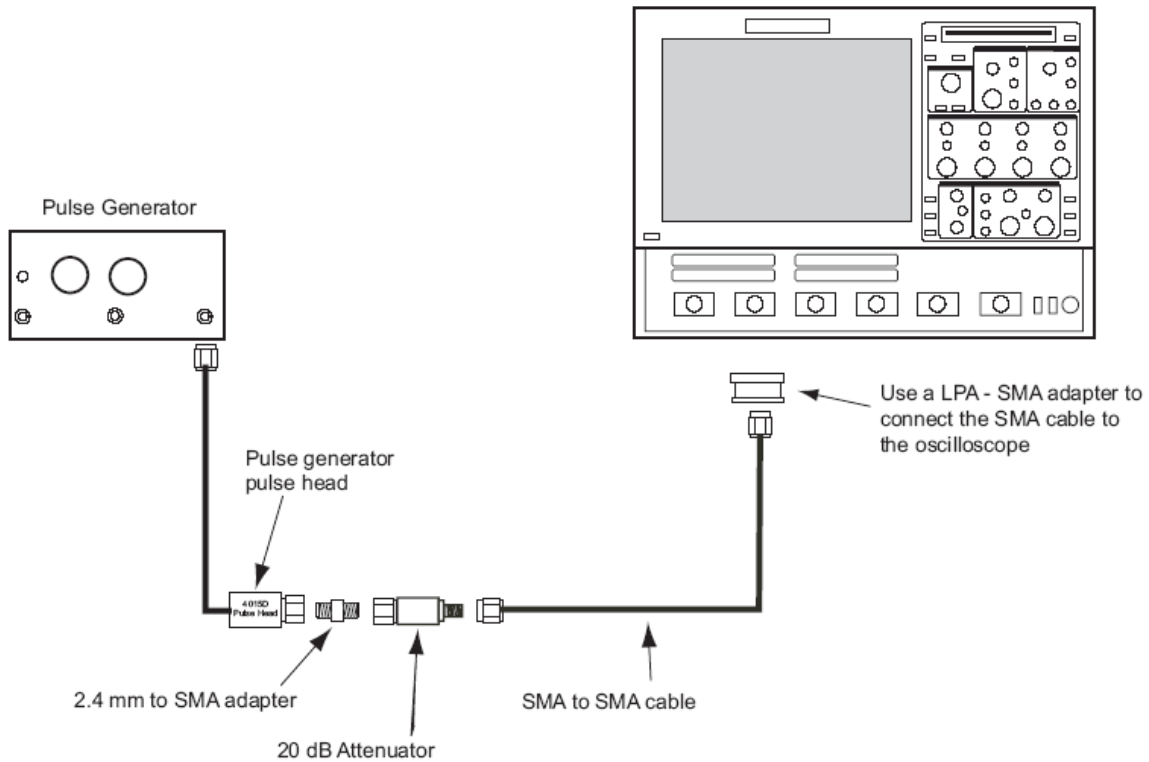

Figure 29. Measuring System Rise Time



CAUTION

When fastening a SMA connector, always use the SMA Torque Wrench to tighten the connector.

- c. Connect the female side of the attenuator via a SMA cable to the LPA–SMA adapter.
- d. Set the oscilloscope vertical to Channel 2, the input coupling to DC and the scale factor to 0.1 V/div.
- e. Select INVERT in the vertical menu.

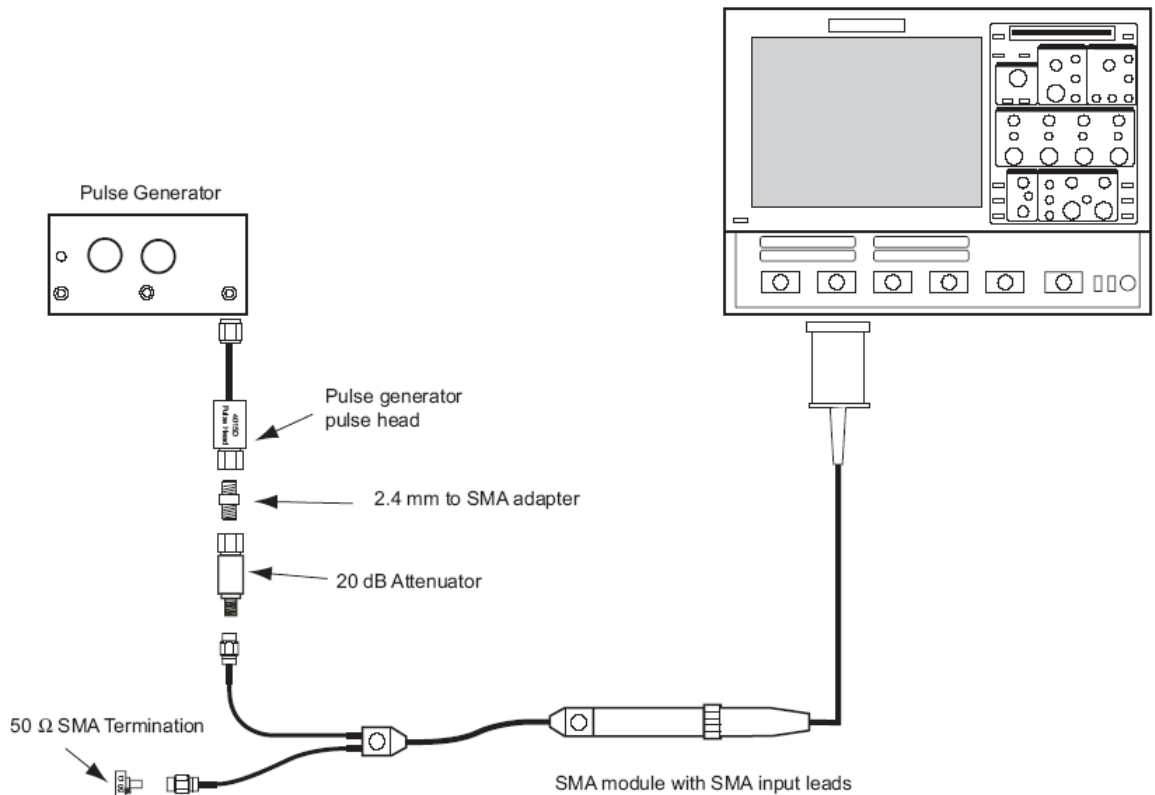

Figure 30. Measuring Probe Rise Time

- f. Set the oscilloscope bandwidth to FULL, triggering from Channel 2, select the RIS method, set the timebase to 20 ps/div and adjust the trigger for a stable display.
- g. Record the measured 10% - 90% rise time as 'System rise time' (t_{sys}) in the Test Record.
- h. To measure the probe's rise time, disconnect the SMA cable from the 20 dB attenuator and remove the LPA-SMA adapter from the oscilloscope.
- i. Connect the + side of the SMA Input Cable to the output of the 20 dB adapter and the output of the probe to channel 2 of the oscilloscope.

WAVELINK DIFFERENTIAL PROBE

- j. Connect the 50 Ω SMA terminator to the – side of the SMA Input Cable.
- k. Use the variable scale factor to obtain a pulse height of about 5 divisions. Adjust the OFFSET to center the displayed pulse around the center graticule line.
- l. Measure the 10% - 90% rise time and record the measurement as 'Rise time with probe' (t_2) in the Test Record.
- m. Calculate the probe's rise time by taking the square root from the difference of $(t_{sys})^2$ and $(t_2)^2$.

$$Probe\ Rise\ Time = \sqrt{(t_2)^2 - (t_{sys})^2}$$

- n. Record the calculated rise time as 'Probe Rise Time' in the Test Record.
- o. Check that the calculated rise time for the D11000PS with SMA module is < 40 psec and the rise time for the D13000PS is < 35 psec.

This concludes the Performance Verification Procedure.

BLANK PAGE

WAVELINK DIFFERENTIAL PROBE

SPECIFICATIONS

The specifications are valid for probes when the following conditions have been met:

- The probe has been operating for at least 30 minutes in an environment, which is within the operating environmental specifications.
- The probe has been calibrated within the last 12 months. Calibration was performed in a controlled environment of $25^{\circ}\text{C} \pm 5^{\circ}\text{C}$.

NOMINAL CHARACTERISTICS

Nominal characteristics describe parameters and attributes that are guaranteed by design, but do not have associated tolerances.

Differential Mode Range $\pm 1\text{ V}$

Common Mode Range

SI Tip $\pm 4\text{ V}$

SMA/SMP Tip $\pm 2\text{ V}$

General

Input Configuration	True differential, + and – Inputs with auxiliary ground connection.
Input Connectors	Solder-In. Damping resistors leads can be soldered directly into any test point on the board.
SI	
SMA	The SMA input leads will connect directly to female SMA connectors on the system under test.
SMP	The SMP input leads will connect directly to female SMP connectors on the system under test.



Maximum Non-Destruct Input Voltage, continuous	± 10 Vp
SI Tip	± 2.5 Vrms,
SMA/SMP Tip	± 10 Vp for < 200ms $\div 3$
Probe Attenuation	40 k Ω differential
Input Resistance (DC)	20 k Ω each input to ground
SI Tip	
Input Impedance	50 Ω , each input
SMA/SMP Tip	
Input VSWR SMA Tip	Each input from DC to 13 GHz
DC - 6 GHz	1.5:1
6 GHz to max frequency	2.0:1

D13000PS/ D11000PS CHARACTERISTICS

Typical characteristics are parameters with no guaranteed performance. Tests for typical characteristics are not provided in the Performance Verification Procedure.

WAVELINK DIFFERENTIAL PROBE

Specifications	D13000PS	D11000PS
Bandwidth (System) ^{1,4}	13 GHz (Typical)	11 GHz (Typical)
Rise Time (System) ^{2,3} (10% - 90%)	<45 psec (Typical)	<50 psec (Typical)
Rise Time (Probe Only) ^{2,3} (10% - 90%)	<35 psec	<40 psec
Attenuation, Nominal	÷ 3	÷ 3
LF Attenuation Accuracy	2% (20 - 30° C)	2% (20 - 30° C)
Output Zero	< 15 mV Referred to Input	< 15 mV Referred to Input
Noise, System ⁵	5 mV _{rms} (Typical)	5 mV _{rms} (Typical)
Differential Mode Range	± 1 V	± 1 V
Common Mode Range ⁶	± 4 V, Solder-In Tip ± 2 V, SMA Cable Input	± 4 V, Solder-In Tip ± 2 V, SMA Cable Input
Input Resistance at DC (Solder-In Lead)	40 kΩ Differential 20 kΩ Each Side to Ground	40 kΩ Differential 20 kΩ Each Side to Ground
Minimum Input Impedance (Solder-In Lead to 13 GHz)	> 175 Ω	> 175 Ω
Input Impedance Each Input (SMA/SMP Cable Input)	50 Ω	50 Ω
Input VSWR (Typical, SMA/SMP Cable Input, Each Lead to Ground)	< 1.5:1 DC – 6 GHz < 2.0:1 6 GHz – 13 GHz	< 1.5:1 DC – 6 GHz < 2.0:1 6 GHz – 11 GHz
CMRR (Typical, see the CMRR Figure, second as follows)	> 40 dB DC – 1 GHz > 30 dB 1 GHz – 4 GHz > 20 dB 4 GHz – 13 GHz	> 40 dB DC – 1 GHz > 30 dB 1 GHz – 4 GHz > 20 dB 4 GHz – 11 GHz
Propagation Delay	7.3 nsec (Typical)	7.3 nsec (Typical)
Gain Variation with Temperature	0.1%/ °C (Typical)	0.1%/ °C (Typical)
Common Mode Voltage Measurement Accuracy	2% ±50 mV (Typical)	2% ±50 mV (Typical)
Total Harmonic Distortion	0.80% (1V p-p input at 4 GHz, Typical)	0.80% (1V p-p input at 4 GHz, Typical)
2 nd Order Intercept (Input)	46 dBm (Measured at 4 GHz, Typical)	46 dBm (Measured at 4 GHz, Typical)
3 rd Order Intercept (Input)	30 dBm (Measured at 4 GHz, Typical)	30 dBm (Measured at 4 GHz, Typical)

Notes:

Unless otherwise noted, all specifications apply to the system performance with either an SI or SMA tip or a 13/11 GHz oscilloscope (SDA 13000/11000).

Several specifications above might be split into SMA Tip / SI Tip specifications if the performance of the two differs.

¹ 20 °C to 30 °C. Measured with an SDA 13000/11000 oscilloscope. Accuracy of oscilloscope channel subtracted from measurement.

² Drift over a 20 minute interval after 20 minute warm-up time and AutoZero is pressed.

³ Measured with a SDA 13000/11000 oscilloscope. Rise time of oscilloscope and source subtracted (RMS).

⁴ Measured with a swept sine wave source or step with FFT. Frequency of oscilloscope channel subtracted from the measurement.

⁵ Measured with an SDA 13000/11000 oscilloscope using SDEV function to remove offset.

⁶ Can be extended by using DC blocking adapters.

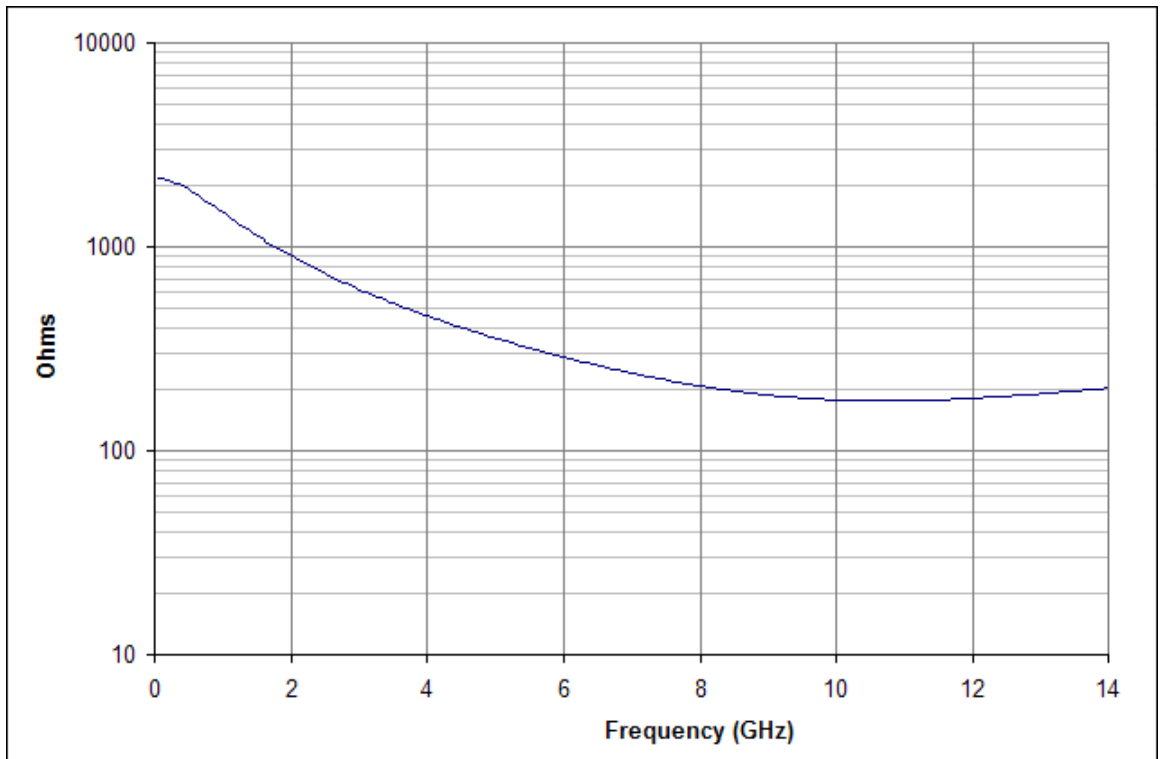

Figure 31. D13000PS/D11000PS Typical Loading Impedance (Differential)

WAVELINK DIFFERENTIAL PROBE

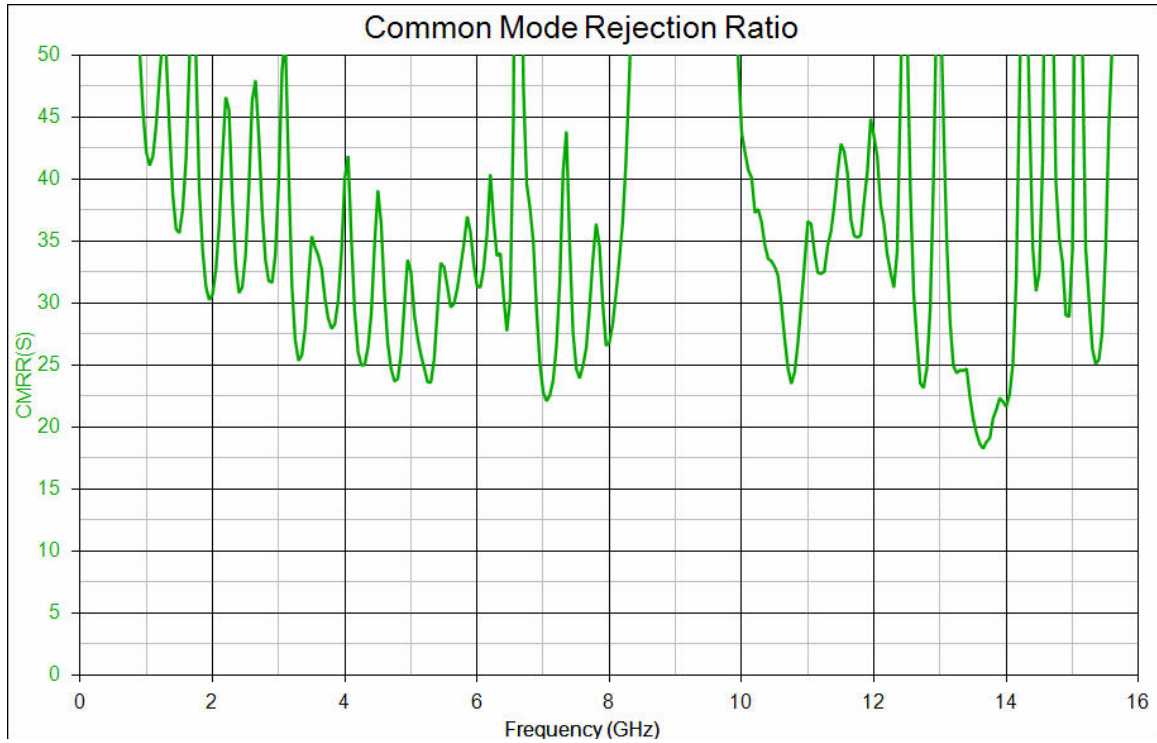

Figure 32. Typical D13000PS/D11000PS CMRR

ENVIRONMENTAL CHARACTERISTICS

The Environmental Characteristics are tested to specification MIL-PRF-28800F Class 4

Temperature (Operating)	0 °C to 40 °C
Temperature (Non-Operating)	-40 °C to 71 °C
Humidity (Operating)	5% to 80% RH* (Non-Condensing) 50% RH above 30 °C
Humidity (Non-Operating)	5% to 95% RH* (Non-Condensing) 75% RH above 30 °C and 45% RH above 40 °C

PHYSICAL CHARACTERISTICS

Cable Length	1.3 m (4 ft. 3 in)
Weight:	
Probe only	194 g (6.9 oz)
Shipping	2.1 kg (4 lbs 9 oz)

COMPLIANCE AND CERTIFICATIONS



CE Compliant

WAVELINK DIFFERENTIAL PROBE

CE Declaration of Conformity

The D13000PS/D11000PS meets the intent of the European Council Directive 73/23/EEC for Product Safety and 89/336/EEC for Electromagnetic Compatibility. This declaration is based upon compliance of the product to the following standards:

Low Voltage Directive:	EN 61010-031:2002 Safety requirements for electrical equipment for measurement, control and laboratory use. Part 031: Safety requirements for handheld probe assemblies for electrical measurements and test.
EMC Directive:	EN 61326-1:1997+Amd1:1998+Amd2:2001 EMC requirements for electrical equipment for measurement, control and laboratory use. EN 55011:1998+Amd1:1999 Radiated Emissions (Class A) EN 61000-4-2:1995+Amd2:2001* Electrostatic Discharge Immunity (± 4 kV contact discharge, ± 8 kV air discharge) EN 61000-4-3:2002* RF Radiated Electromagnetic Field Immunity (3 V/m, 30 MHz to 1 GHz, 80% amplitude modulated with 1 kHz sinewave)

* Meets Performance Criteria "B" limits – temporary, self-recoverable degradation or loss of performance is allowed, but no change of actual operating state or loss of stored data is allowed.



CAUTION

This is a Class A product. In a domestic environment this product may cause radio interference, in which case the user may be required to take appropriate measures.

APPENDIX

PERFORMANCE VERIFICATION TEST RECORD

This record can be used to record the results of measurements made during the performance verification of the D13000PS/D11000PS Differential Probe System. Photocopy this page and record the results on the copy. File the completed record as required by applicable internal quality procedures. The section in the test record corresponds to the parameters tested in the performance verification procedure. The numbers preceding the individual data records correspond to the steps in the procedure that require the recording of data. Results to be recorded in the column labeled "Test Result" are the actual specification limit check. The test limits are included in all of these steps. Other measurements and the results of intermediate calculations that support the limit check are to be recorded in the column labeled "Intermediate Results". Permission is granted to reproduce these pages for the purpose of recording test results.

Use a new Test Record for each tested probe, probe tip module and lead assembly

ITEMS TESTED

Item	Serial Number
D13000PS	
SMA Module	
Solder-In Module	

Item	Serial Number
D11000PS	
SMA Module	
Solder-In Module	

WAVELINK DIFFERENTIAL PROBE

EQUIPMENT USED

	MODEL	SERIAL NUMBER	CALIBRATION DUE DATE
OSCILLOSCOPE			
DIGITAL MULTIMETER			
SINEWAVE GENERATOR			
PULSE GENERATOR			

TEST RECORD

Step – Description	Intermediate Data	Test Result
Actual Probe Attenuation		
1-k Actual Probe Attenuation		
Output Zero		
2-f Output Voltage	V	
2-h Output Voltage after AutoZero	V	
2-j Output Zero (Test limit ≤ 15 mV)		mV
Attenuation Accuracy		
3-n Input Voltage	V	
3-p Output Voltage	V	
3-q Corrected Output Voltage	V	
3-s Attenuation Error (Test limit $\leq 2\%$)		%
Rise Time		
4-g System rise time	psec	
4-l Rise time with probe	psec	
4-n Probe Rise Time (< 40 psec)		psec

CHINA RoHS COMPLIANCE

部件名称	有毒有害物质和元素					
	铅 (Pb)	汞 (Hg)	镉 (Cd)	六价铬 (Cr6+)	多溴联苯 (PBB)	多溴二苯醚 (PBDE)
PCBAs	X	O	X	X	X	X
机械硬件	O	O	X	O	O	O
金属片	O	O	X	O	O	O
塑料部件	O	O	O	O	X	X
保护外壳	O	O	O	O	X	X
电缆组件	X	O	X	O	X	X
探头端部	X	O	X	O	X	X
<p>O: 表明该有毒有害物质在该部件所有均质材料中的含量均在SJ/T11363-2006标准规定的限量要求之下。</p> <p>X: 表明该有毒有害物质至少在该部件的某一均质材料中的含量均在SJ/T11363-2006标准规定的限量要求。</p>						

EFUP (对环境友好的使用时间) 使用条件：参阅本手册“规范”部分规定的环境条件。

WAVELINK DIFFERENTIAL PROBE

Part Name	Toxic or Hazardous Substances and Elements					
	Lead (Pb)	Mercury (Hg)	Cadmium (Cd)	Hexavalent Chromium (Cr6+)	Polybrominated Biphenyls (PBB)	Polybrominated Diphenyl Ethers (PBDE)
PCBAs	X	O	X	X	X	X
Mechanical Hardware	O	O	X	O	O	O
Sheet Metal	O	O	X	O	O	O
Plastic Parts	O	O	O	O	X	X
Protective Case	O	O	O	O	X	X
Case Assemblies	X	O	X	O	X	X
Probe Tips	X	O	X	O	X	X
<p>O: Indicates that this toxic or hazardous substance contained in all of the homogeneous materials for this part is below the limit requirement specified in SJ/T11363-2006.</p> <p>X: Indicates that this toxic or hazardous substance contained in at least one of the homogenous materials used for this part is above the limit requirement specified in SJ/T11363-2006.</p>						

EFUP (Environmental Friendly Use Period) Use Conditions: Refer to the environmental conditions stated in the specifications section of this Manual.